

VENTS LD Series



Axial decorative fans for exhaust ventilation with the capacity up to 310 m³/h

Applications

- Continuous or periodic exhaust ventilation of bathroom, showers, kitchens and other utility spaces.
- Ventilation shaft mounting or duct connection.
- Low to medium air flow motion for short distances at low air resistance.
- Compatible with Ø 100, 125 and 150 mm air ducts.

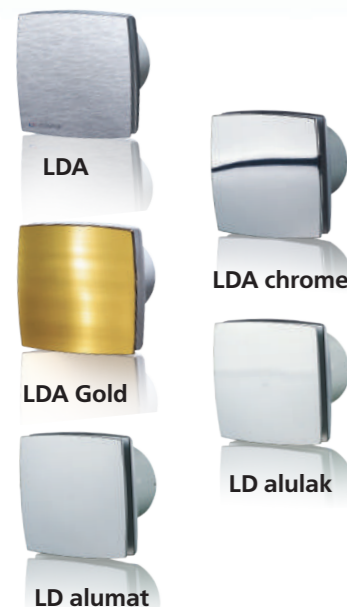

Design

- Modern design and aesthetic look.
- The casing and the impeller are made of high-quality durable ABS plastic, UV resistant.
- Various decorative plates for the front panel of the natural aluminum.
- The intellectual impeller design makes the fan efficiency high and the service life long.
- Protection rating IP 34.

Motor

- Reliable and low-watt electric motor.
- Designed for continuous operation and requires no maintenance.
- Equipped with overheating protection.

Modifications and Options

LDA – the fan with a ground aluminium front panel.

LDA gold – the fan with a gold-tinted aluminium front panel.

LDA chrome – the fan with a mirror finish aluminium front panel.

LD alumat - the fan with a front panel painted silver (matt).

LD alulak – the fan with a front panel painted silver (gloss).

LD1 – shortened branch pipe model.

LDK – fan is equipped with a backdraft damper for back flow preventing.

LDL – the motor is equipped with ball bearings for long service life (appr. 40 thousand hours) and fan mounting at any angle. The bearings are maintenance-free and contain enough grease for the entire operating period.

LD turbo – high-powered motor.

LD 12 – modification with low-voltage motor. 12 V AC power supply.

LDT – equipped with a regulated timer with the operating time from 2 to 30 minutes.

LDTH – equipped with a timer with the operating time from 2 to 30 minutes and a humidity sensor with the threshold value from 60 to 90%.

LDV – equipped with a pull cord switch.

LDVT – equipped with a pull cord switch and a regulated timer with the operating time adjustable from 2 to 30 minutes.

LDVTH – equipped with a pull cord switch, regulated timer with the operating time adjustable from 2 to 30 minutes and a humidity sensor with the operating threshold range from 60% to 90%.

Control

Manual:

- The fan is controlled by a room light switch. It is not included in the delivery package.
- The fan is controlled by the built-in pull cord switch **V**. Not applied in case of ceiling mounting.
- Speed control is possible through a thyristor speed controller (see Electrical Accessories). Several fans may be connected to the same controller. Speed controllers can not be connected to the fans with T, TH, TP, VT, VTH modification.

Automatic:

- By the electronic control unit **BU-1-60** (see Electrical Accessories). The control unit is supplied separately.
- By the timer **T** (the built-in run-out timer enables the fan operation within 2 to 30 minutes after the fan switching off).
- By the humidity sensor and timer **TH** (if the humidity level in the room exceeds the sensor threshold adjustable value within 60-90% the fan switches automatically on and operates until the humidity level drops to the standard level, after that the fan continues operating within the time period according to the timer setting, then shuts down).

Mounting features

- The fan is mounted directly into the ventilation shaft.
- Flexible duct application is recommended in case of remote location of the ventilation shaft. The air duct is connected to the fan exhaust flange through a clamp.
- Fixed to wall by self-tapping screws.
- Suitable for ceiling mounting.
- For 12 V low-voltage motor fan connection to 220 V / 50 Hz power mains use the step-down transformer TRF 220/12-25 that is available upon separate order.

Aerodynamic characteristics

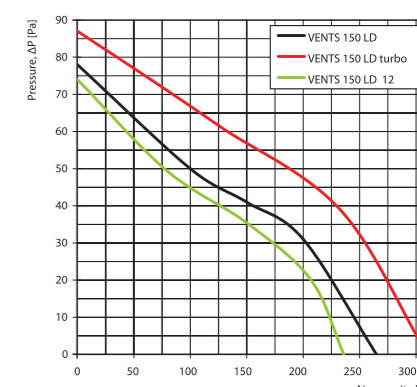
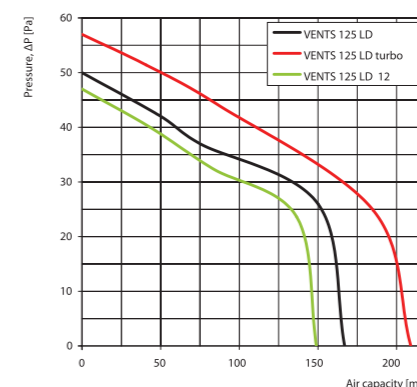
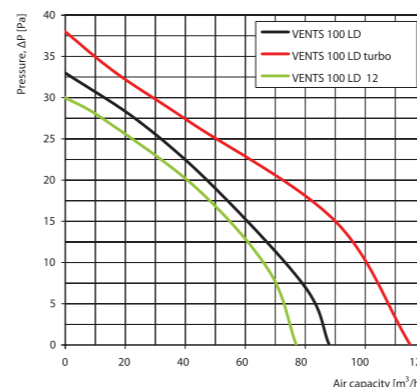

Technical data

Model	Voltage [V] at 50 Hz	Power Consumption [W]	Current [A]	r.p.m.	Maximum air capacity [m ³ /h]	Sound Pressure Level at 3 m [dB(A)]	Weight [kg]
VENTS 100 LD	220-240	14	0,085	2300	88	33	0,60
VENTS 125 LD	220-240	16	0,1	2400	167	34	0,74
VENTS 150 LD	220-240	24	0,13	2400	265	37	0,96
VENTS 100 LD turbo	220-240	16	0,1	2300	115	36	0,68
VENTS 125 LD turbo	220-240	24	0,105	2400	209	36	0,84
VENTS 150 LD turbo	220-240	30	0,13	2400	310	39	1,10
VENTS 100 LD 12	12	14	1,5	2200	77	32	0,59
VENTS 125 LD 12	12	16	1,7	2300	149	33	0,72
VENTS 150 LD 12	12	24	2	2300	236	36	0,92

Mounting example



Overall dimensions

Model	Dimensions [mm]				
	Ø D	B	H	L	L1
VENTS 100 LD	100	152	120	126	30
VENTS 100 LD1	100	152	120	111	30
VENTS 125 LD	125	177	140	135	34
VENTS 125 LD1	125	177	140	116	34
VENTS 150 LD	150	206	165	154	36

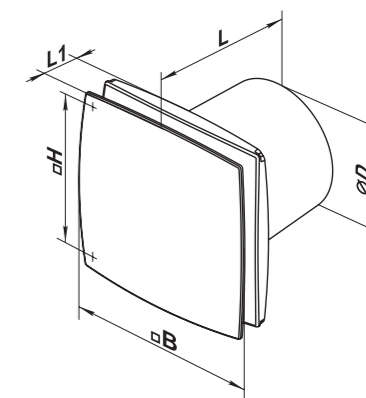

Accessories



Certificates

