

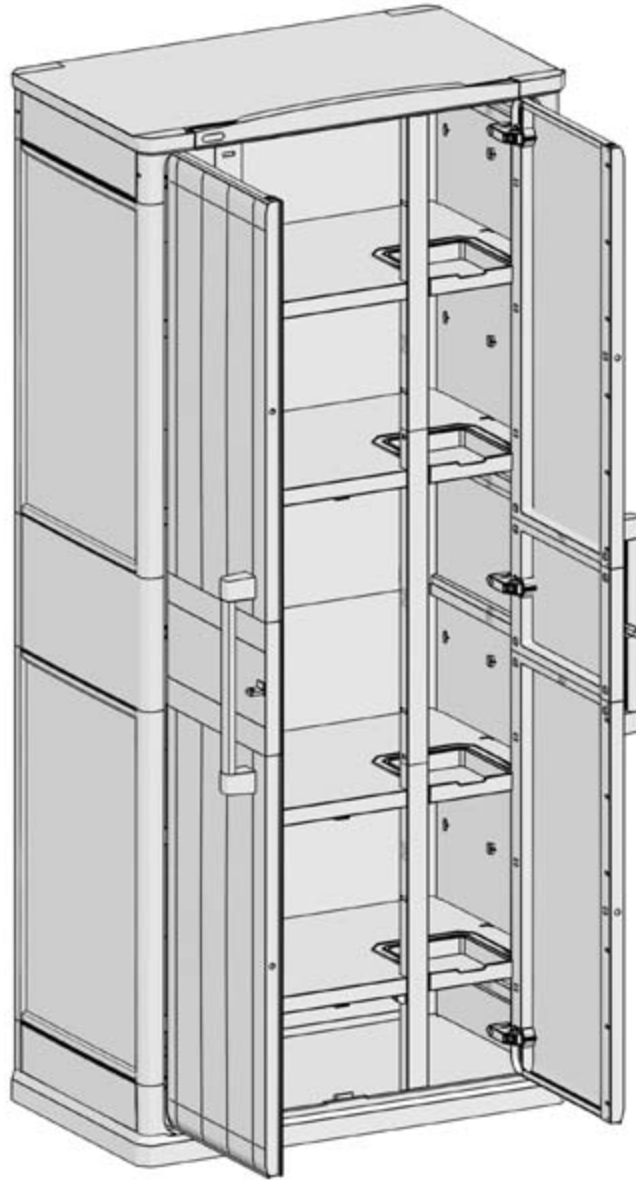

# OPTIMA WONDER™ Outdoor Multipurpose Cabinet

EN ASSEMBLY INSTRUCTIONS FR INSTRUCTIONS DE MONTAGE GE MONTAGEANLEITUNG NL MONTAGEVOORSCHRIFT  
ES INSTRUCCIONES DE MONTAJE IT ISTRUZIONI DI MONTAGGIO PT INSTRUÇÕES DE MONTAGEM GR ΟΔΗΓΙΕΣ ΣΥΝΑΡΜΟΛΟΓΗΣΗΣ



A-2255 / 570093

- EN** IMPORTANT: Please contact Customer Service if you have any problems or discover any missing parts.
- FR** IMPORTANT: Veuillez contacter notre Service Clientèle pour tout problème ou pièce manquante.
- GE** WICHTIG: Bitte wenden Sie sich an unseren Kundenservice, falls Sie irgendwelche Probleme haben oder feststellen, daß Teile fehlen.
- ES** IMPORTANTE: Sírvase contactar con nuestro Servicio al Cliente por cualquier problema, o pieza que pudiera faltar.
- IT** IMPORTANTE: Si prega di contattare il Servizio Clienti per eventuali necessità.
- NL** BELANGRIJK: Neemt u in geval van problemen of missende onderdelen a.u.b. contact op met de klantenservice.
- PT** IMPORTANTE: favor entrar em contato com o Serviço ao Cliente se houver problemas ou se faltar peças.
- GR** ΣΗΜΑΝΤΙΚΟ: παρακαλώ επικοινωνήστε με την Εξυπηρέτηση Πελατών αν αντιμετωπίσετε κάποιο πρόβλημα ή αν λείπει μέρος από την συσκευασία.



**USA & Canada:** 1-(888)-374-4262

**UK:** Tel: 0121-5060008, Fax: 0121-4220808

**Other European Countries:** Tel: +31-1612-28301, Fax: +31-1612-28322

[WWW.KETER.COM](http://WWW.KETER.COM)

ASSEMBLY PARTS | PIÈCES À ASSEMBLER | PIEZAS DE ENSAMBLE | MONTAGETEILE | MONTAGESTUKKEN | PARTI DA MONTARE | PEÇAS DE MONTAGEM | ΑΝΤΑΛΛΑΚΤΙΚΑ ΣΥΝΕΛΕΥΣΗ

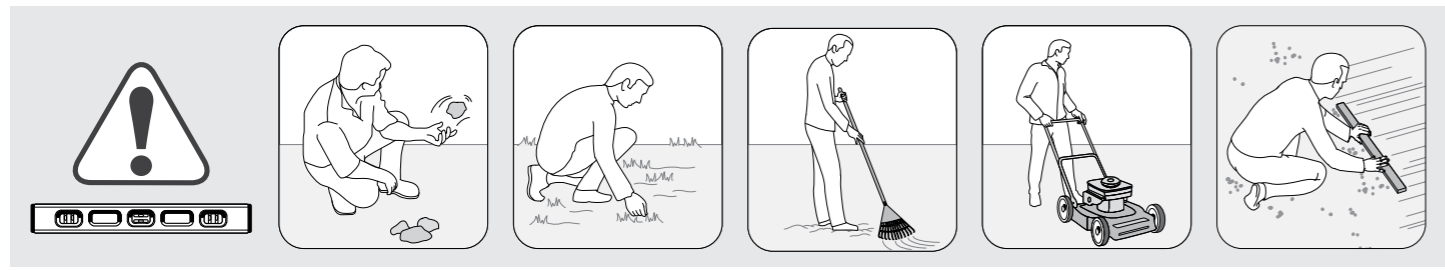
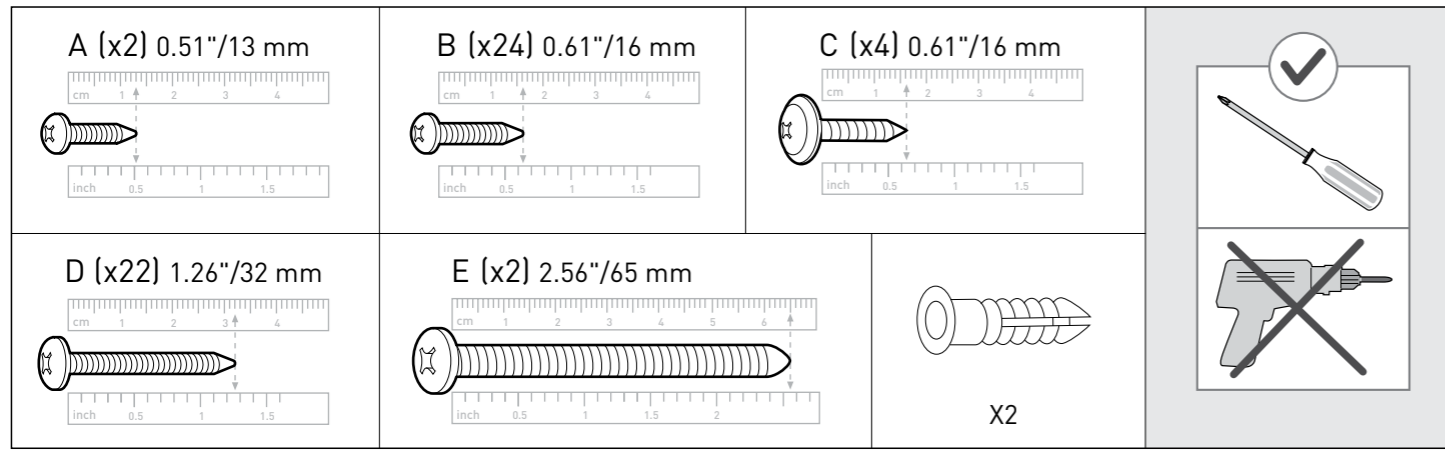
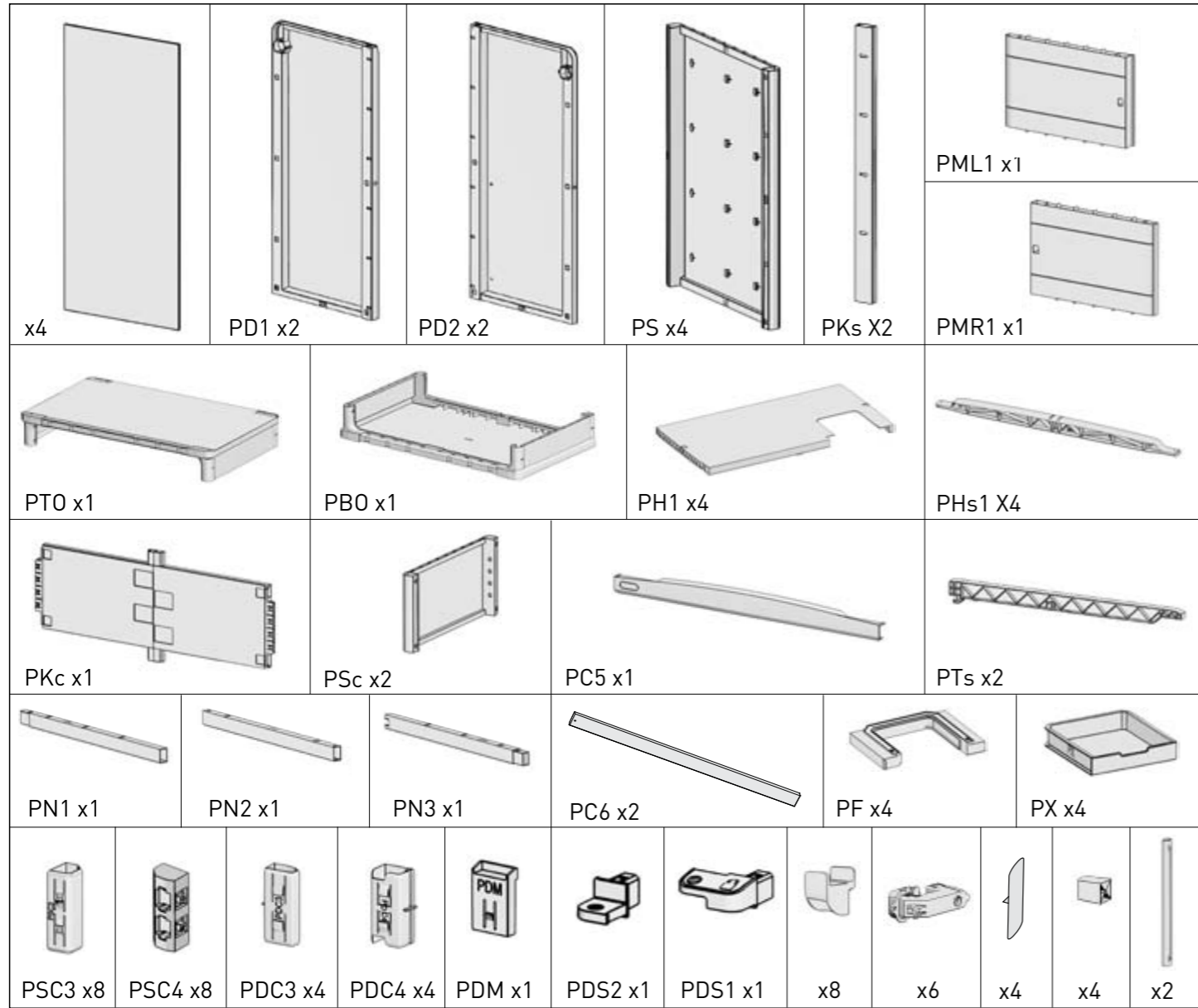

1

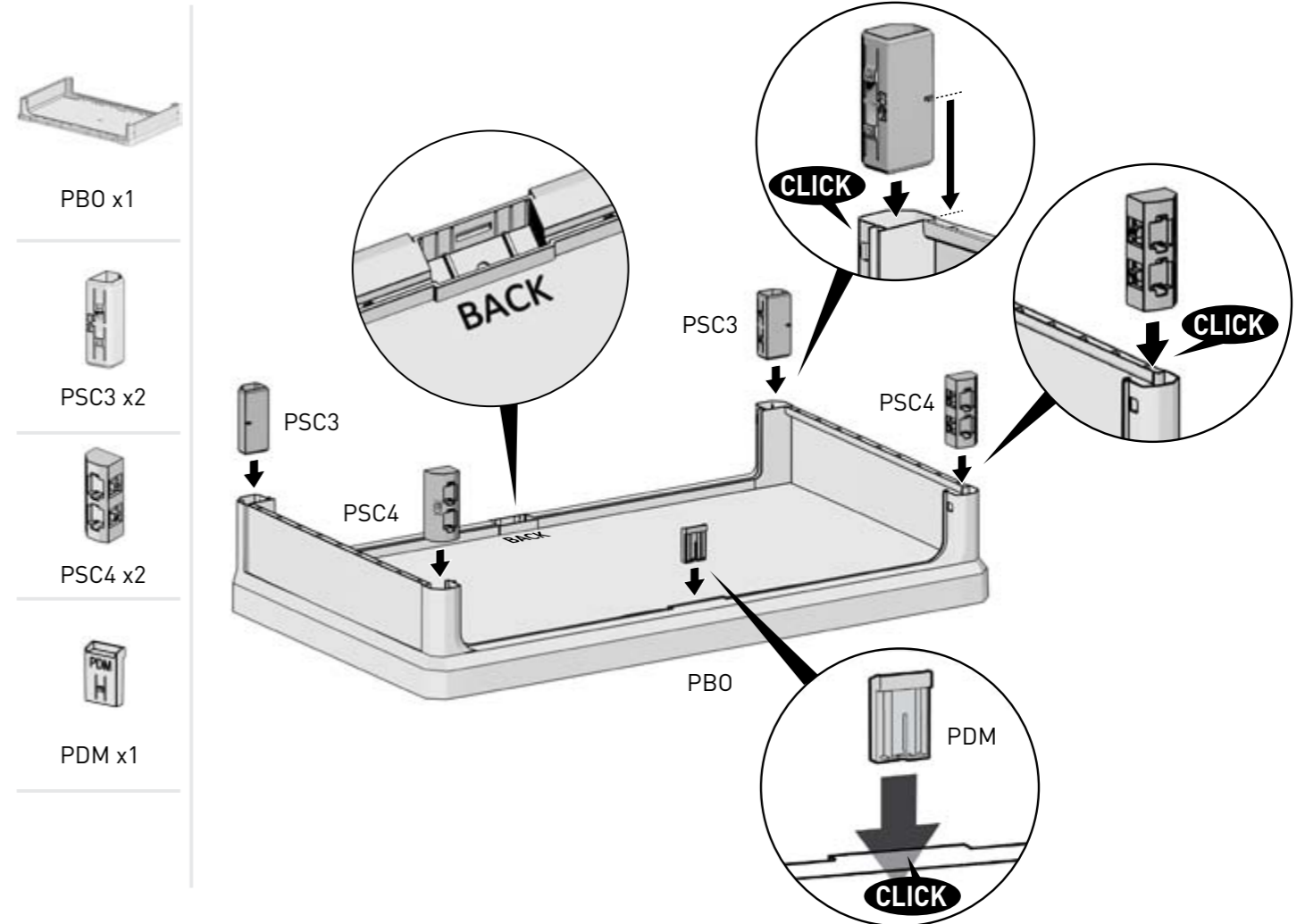

2

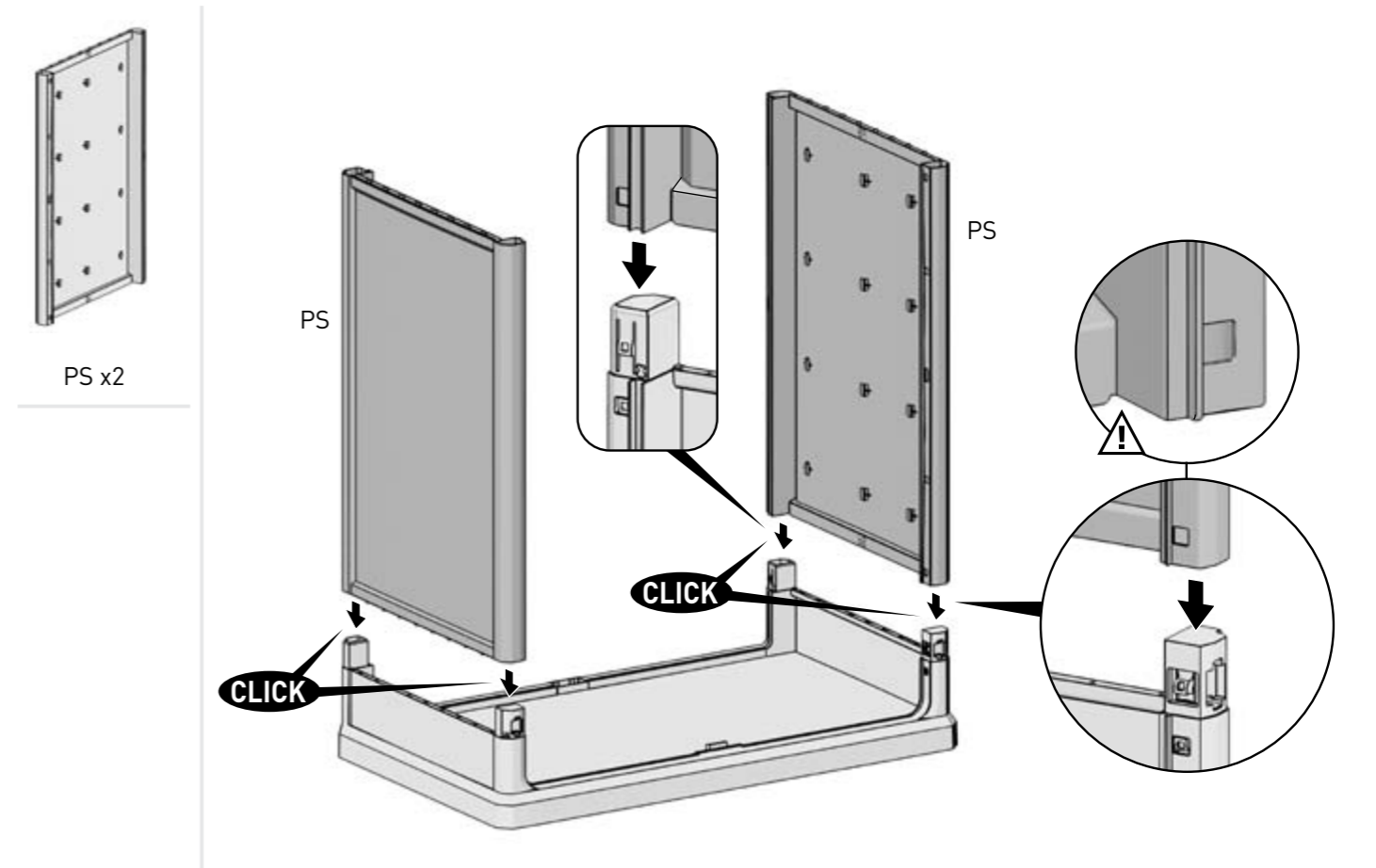

3

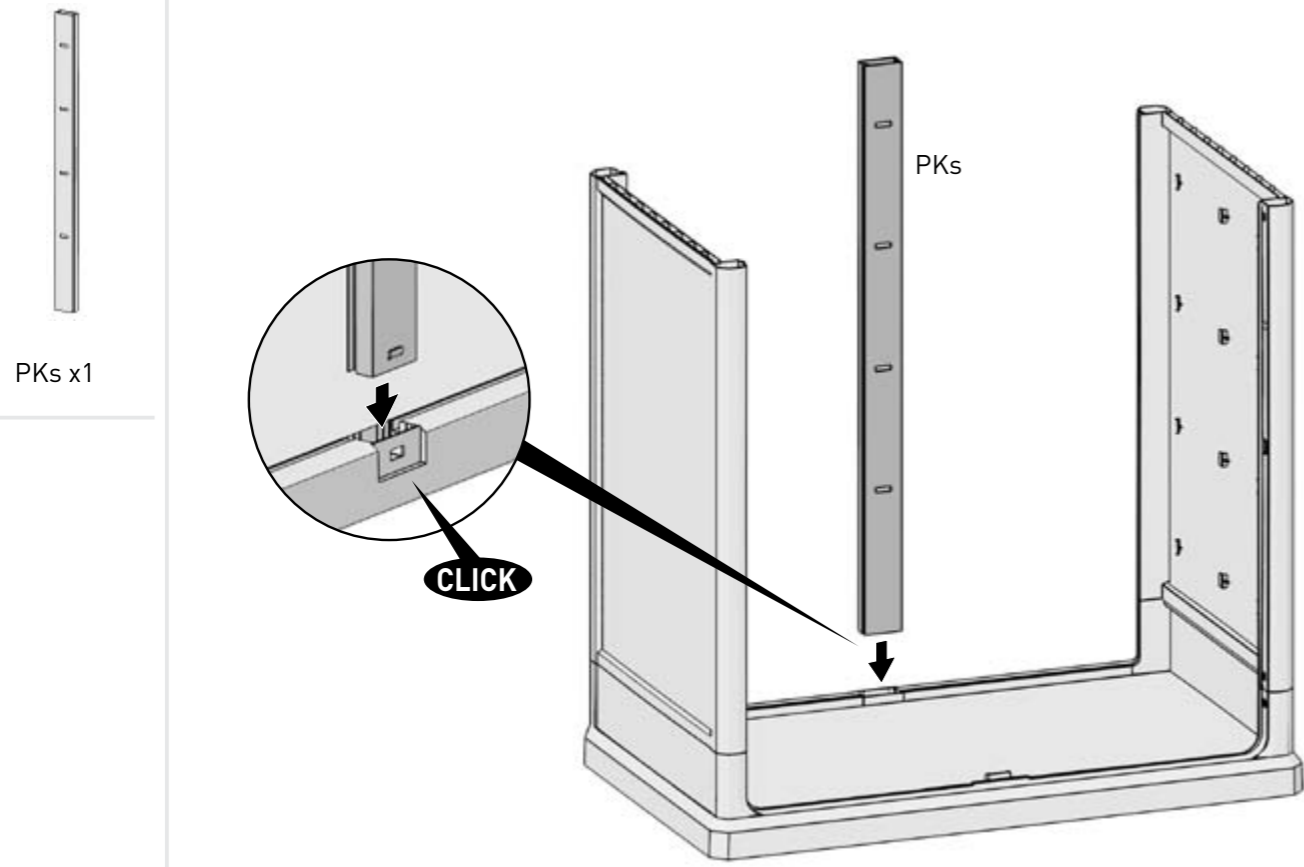

5

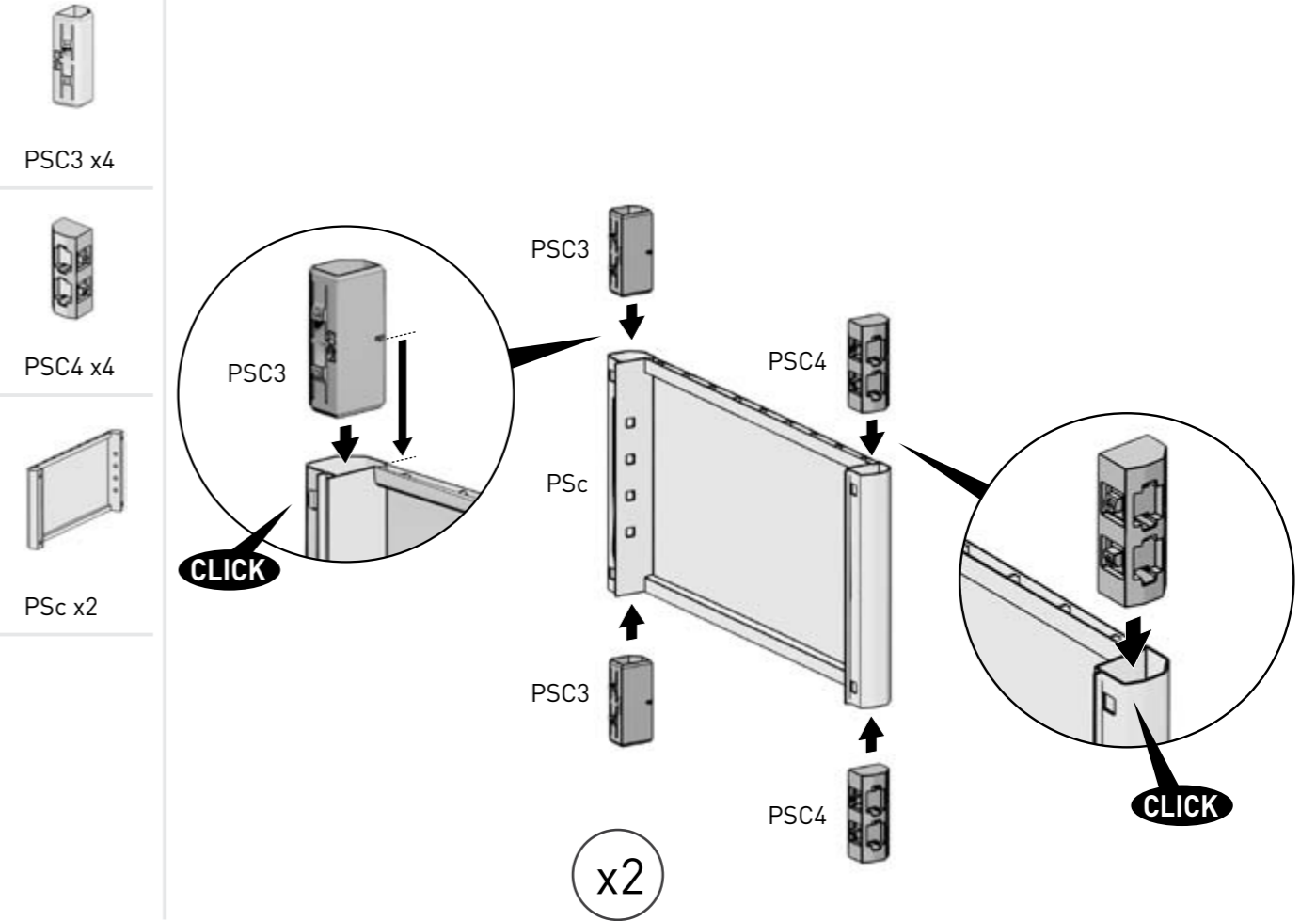

4

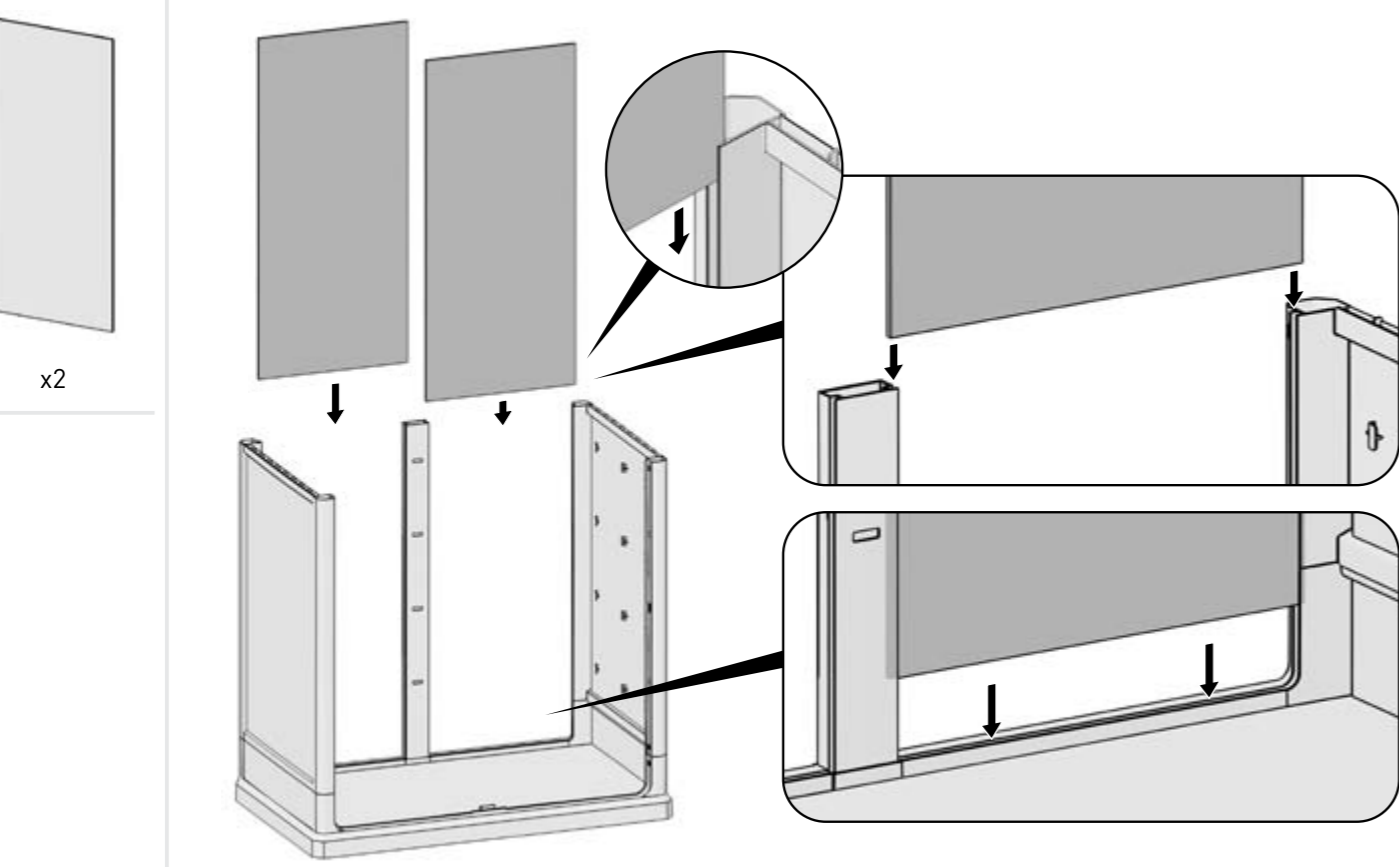

6

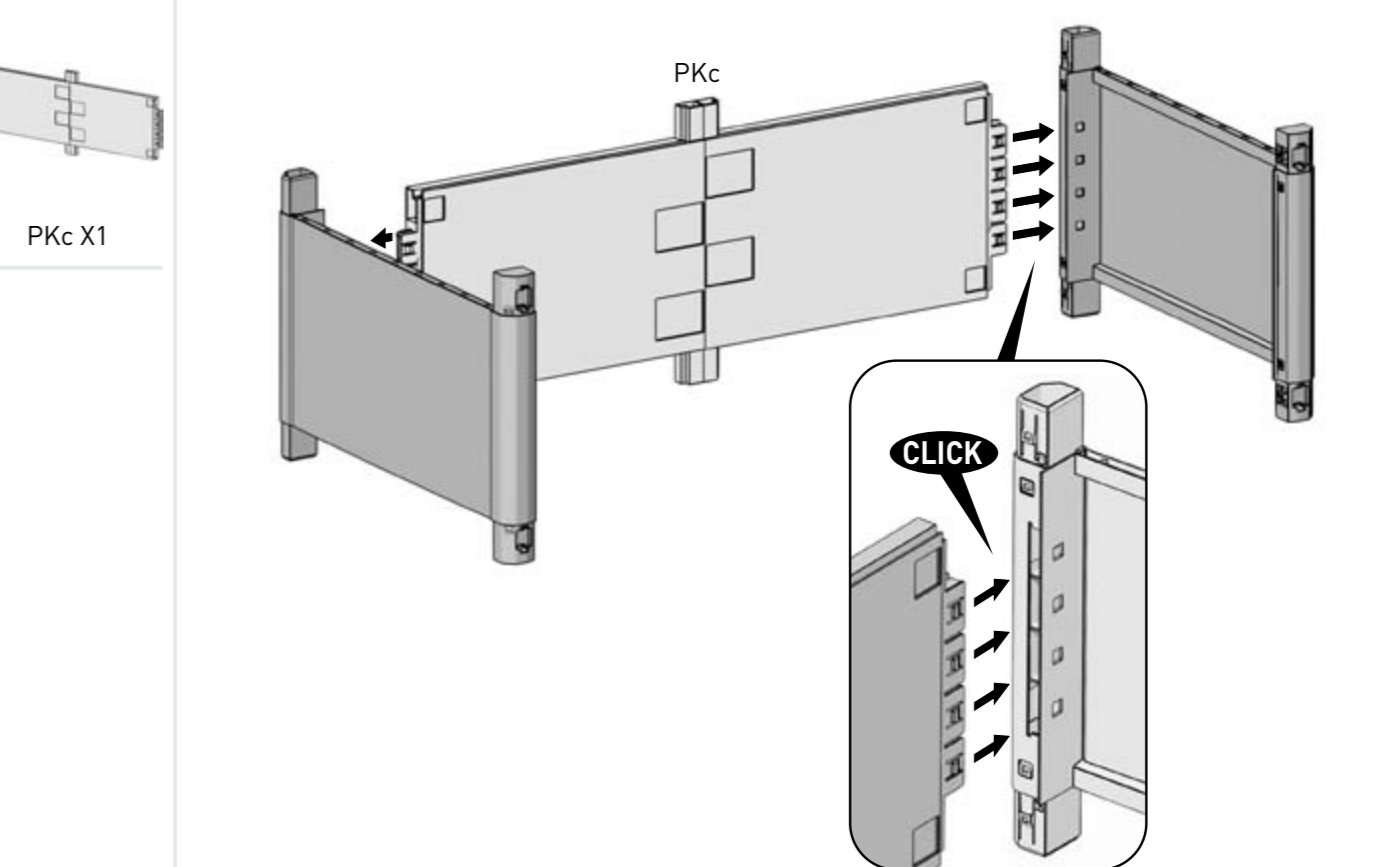

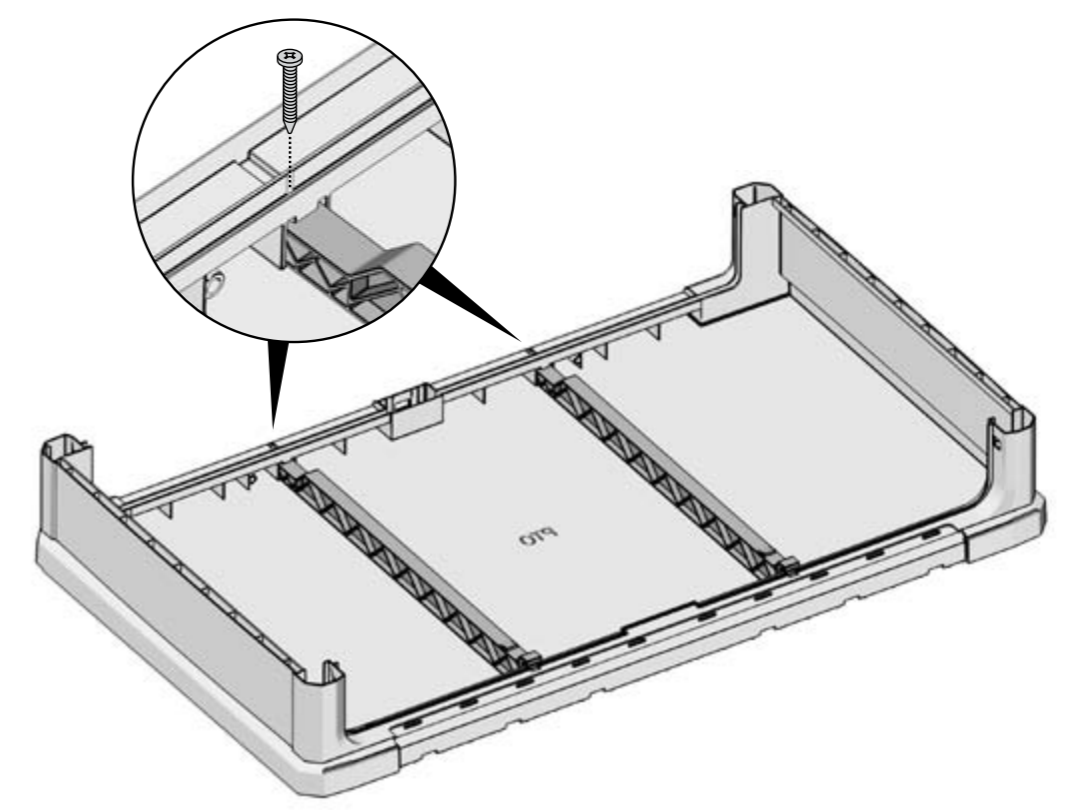
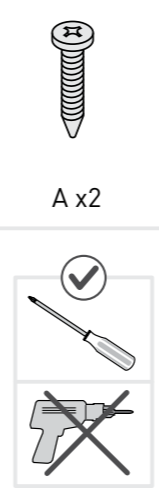
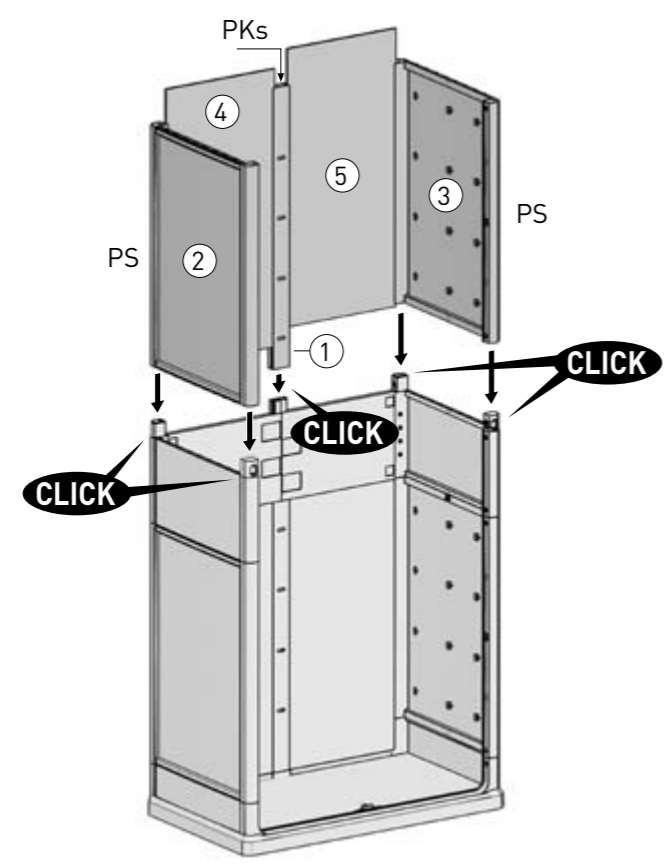
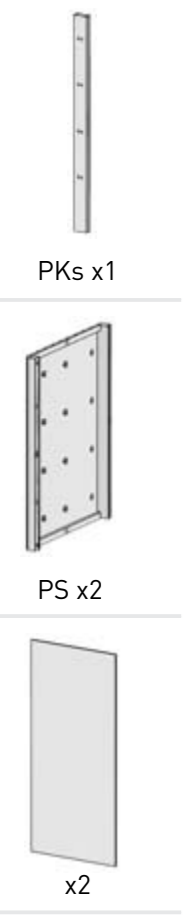
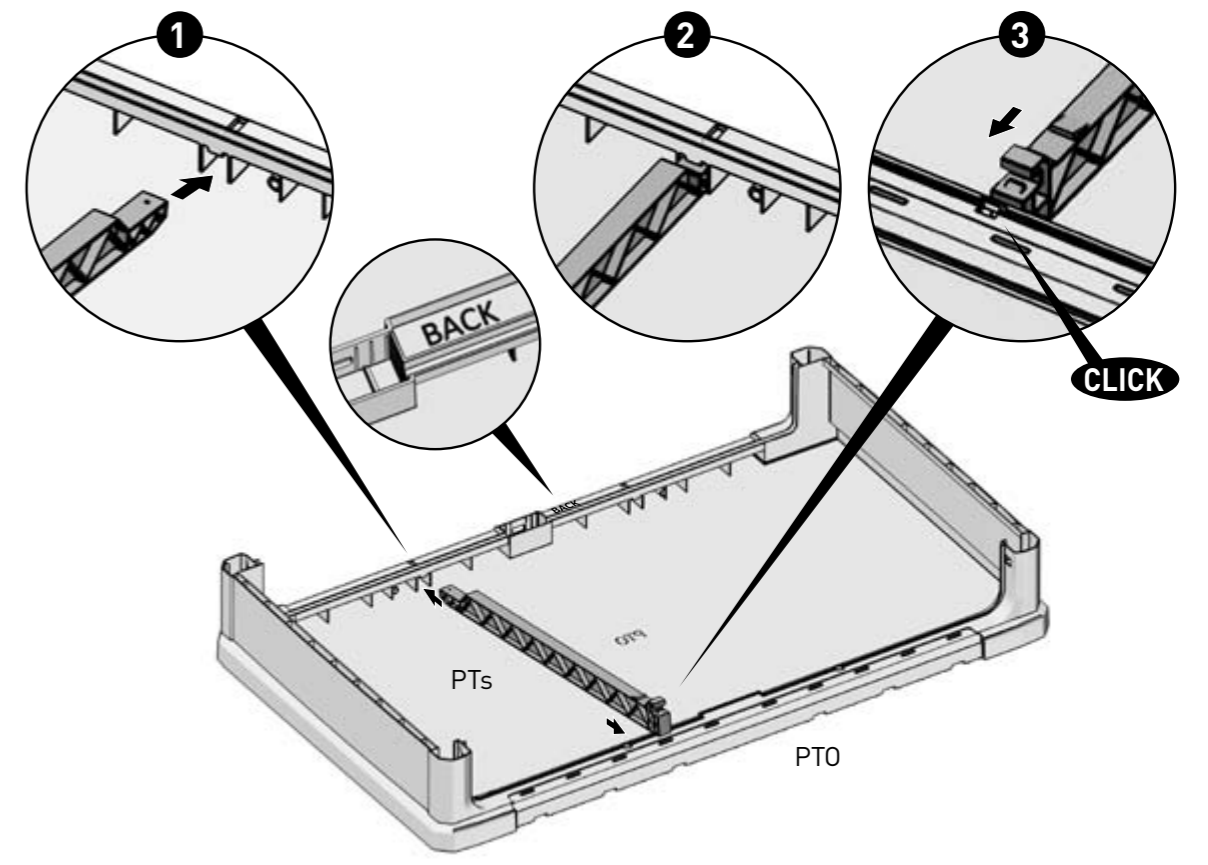
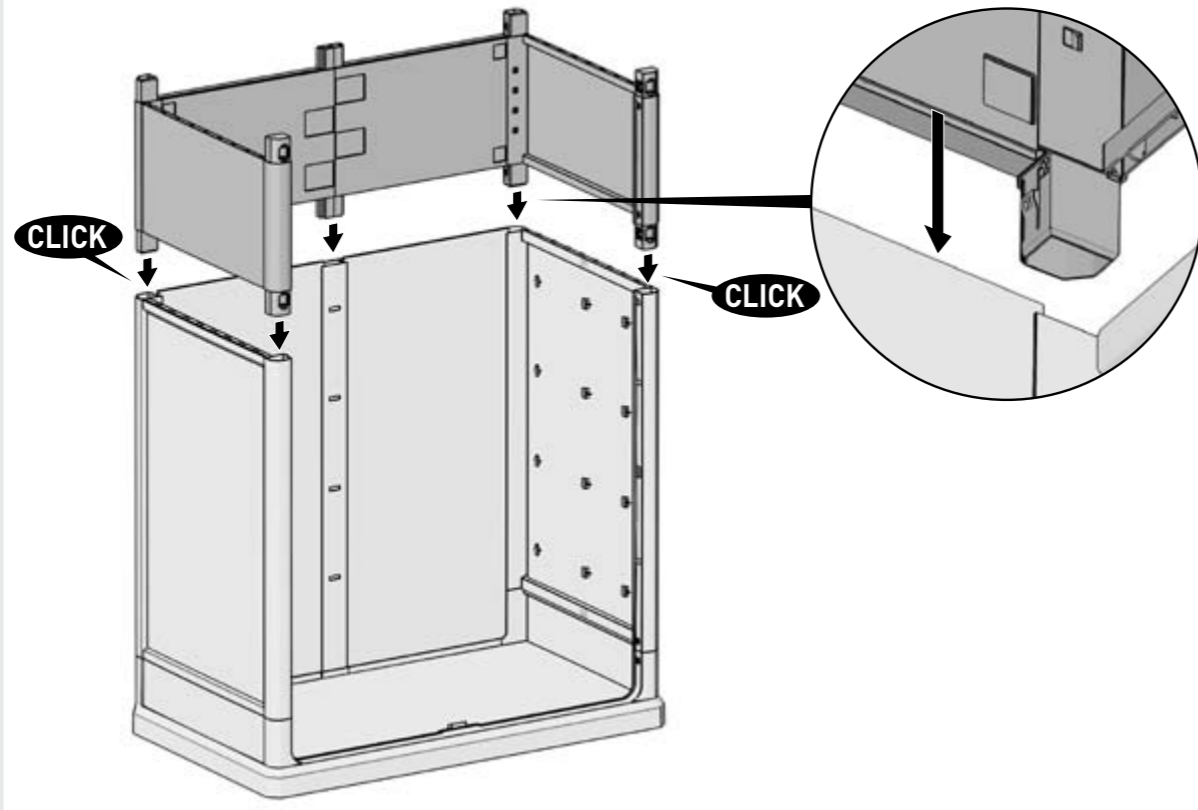



PSC3 x2



PSC4 x2

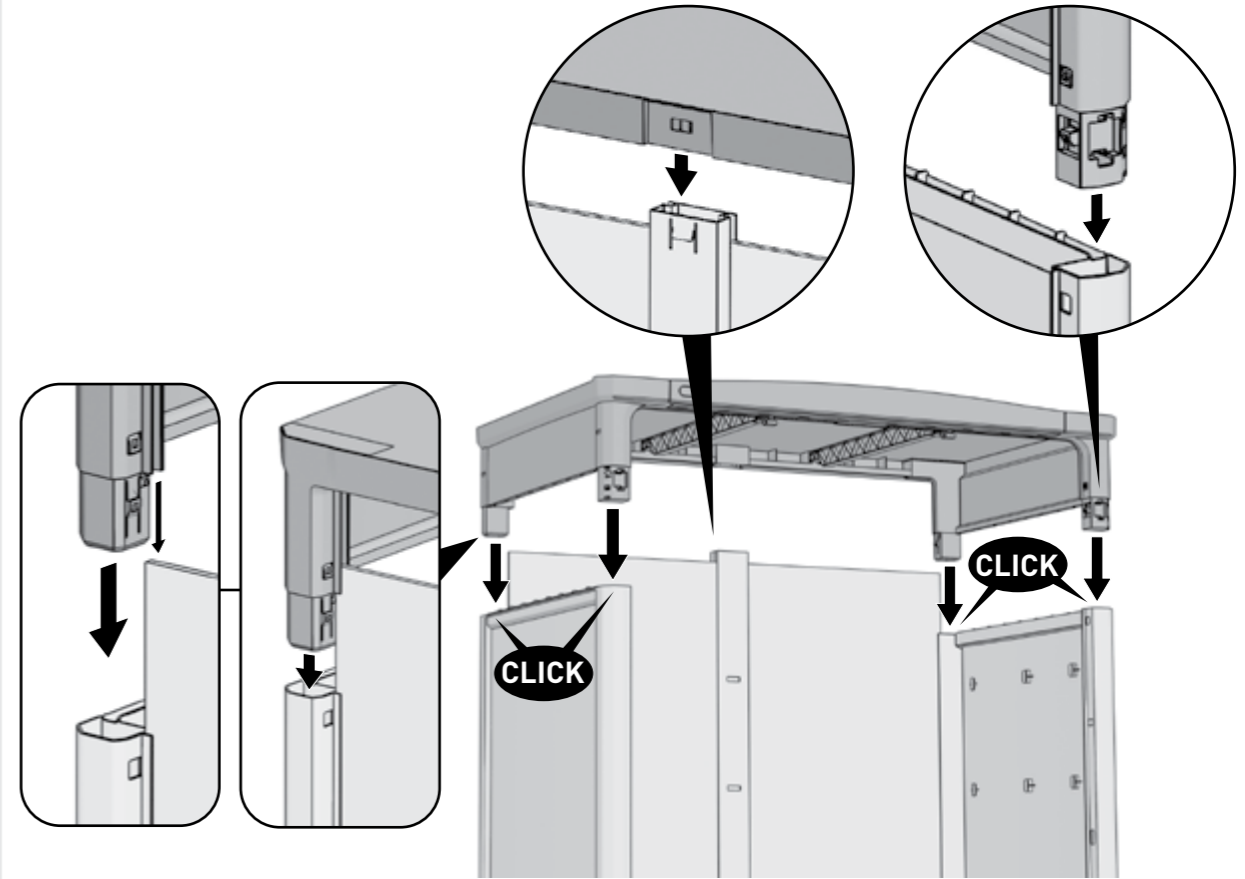
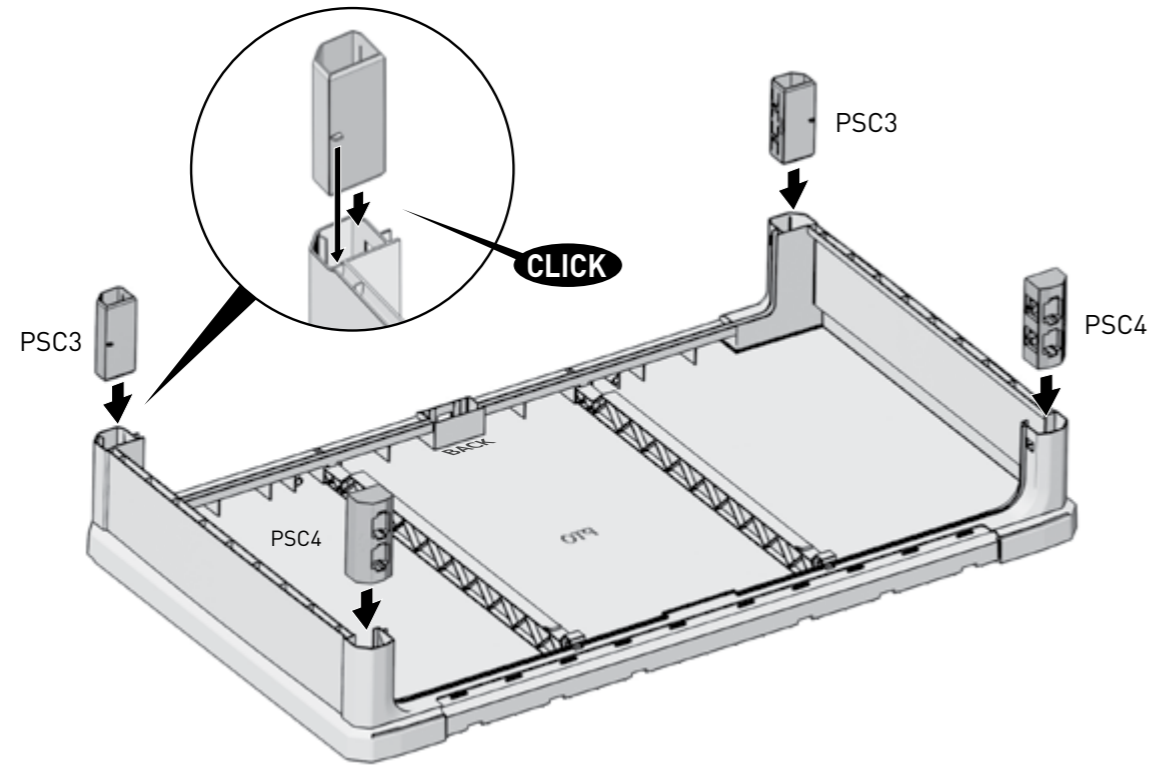

PT0 x1



PC5 x1

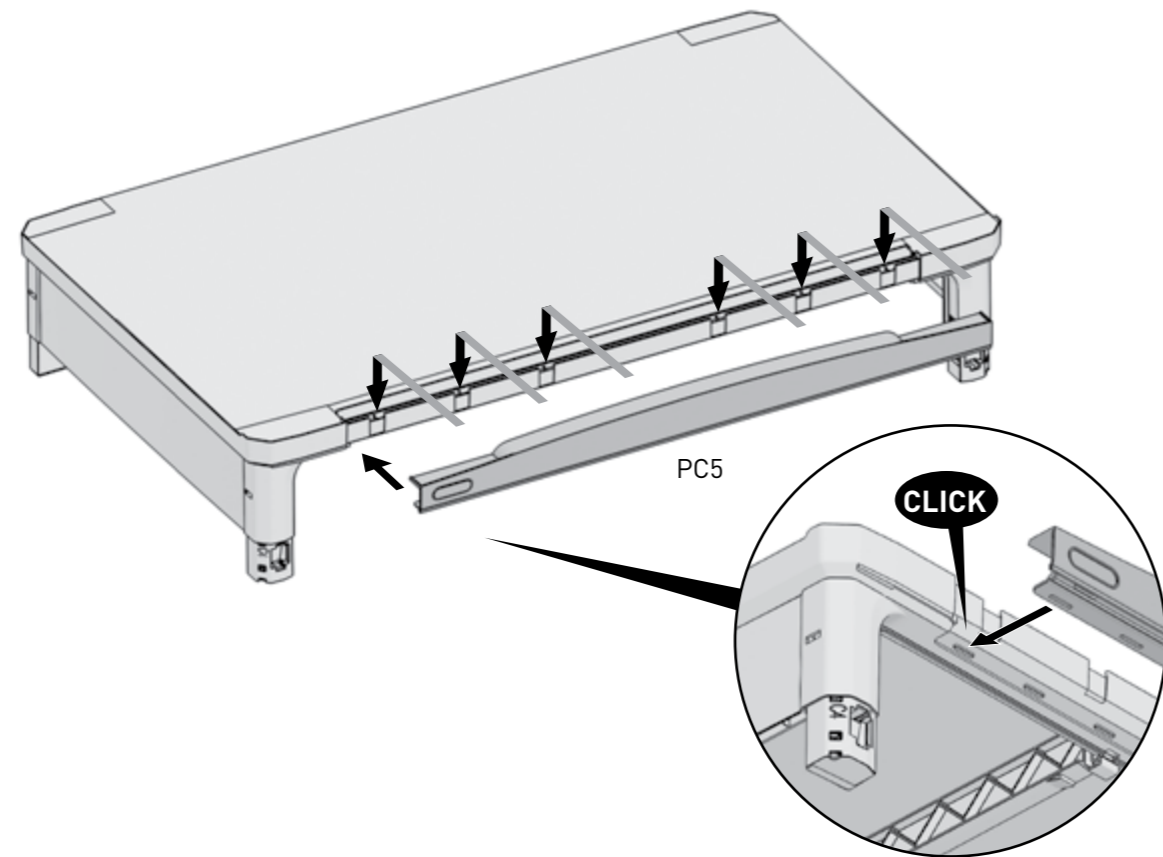

PDC4 x4



PDC3 x4



PML1 x1



PMR1 x1

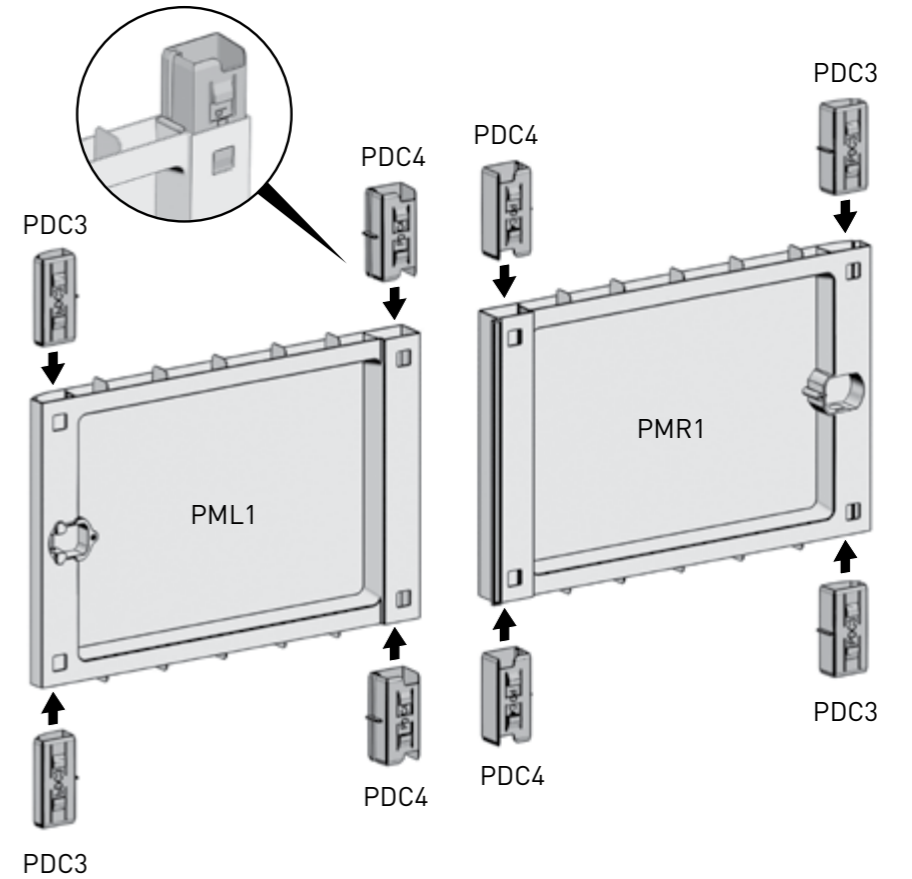



PD1 x1 PD2 x1



PML1 x1



x3



B x3

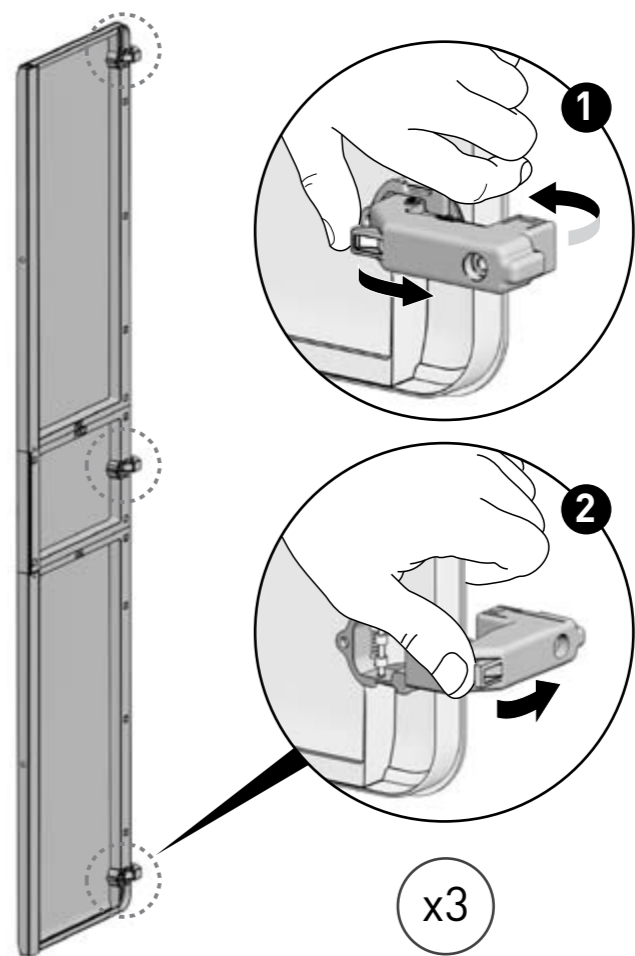
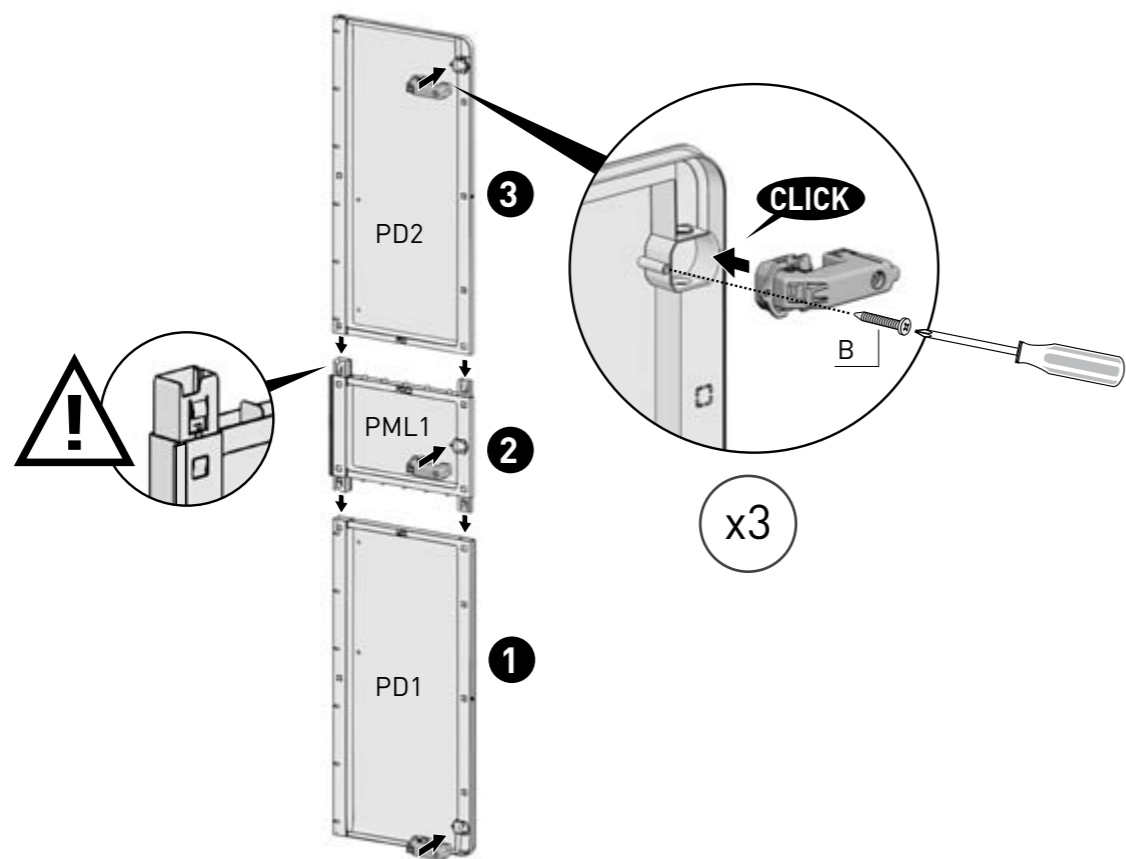
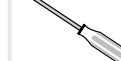

PC6 x2

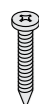

B x2

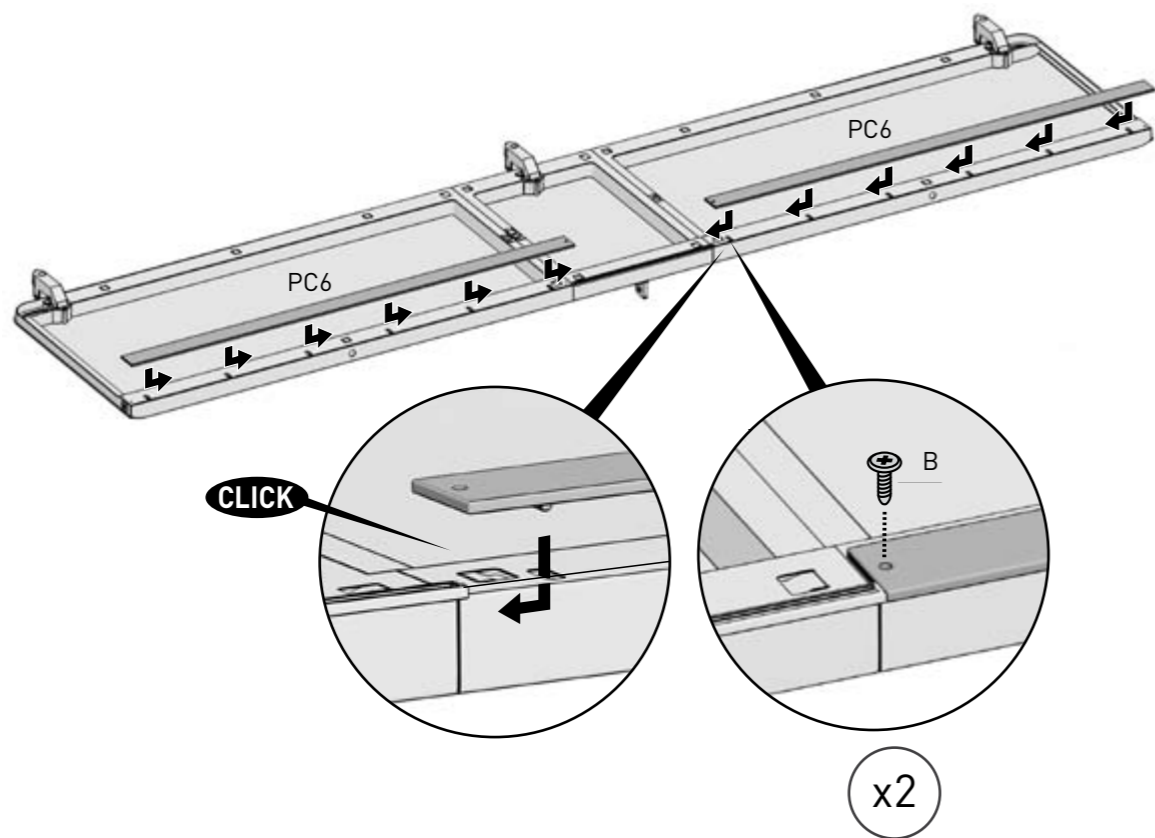
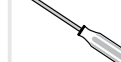

D x3

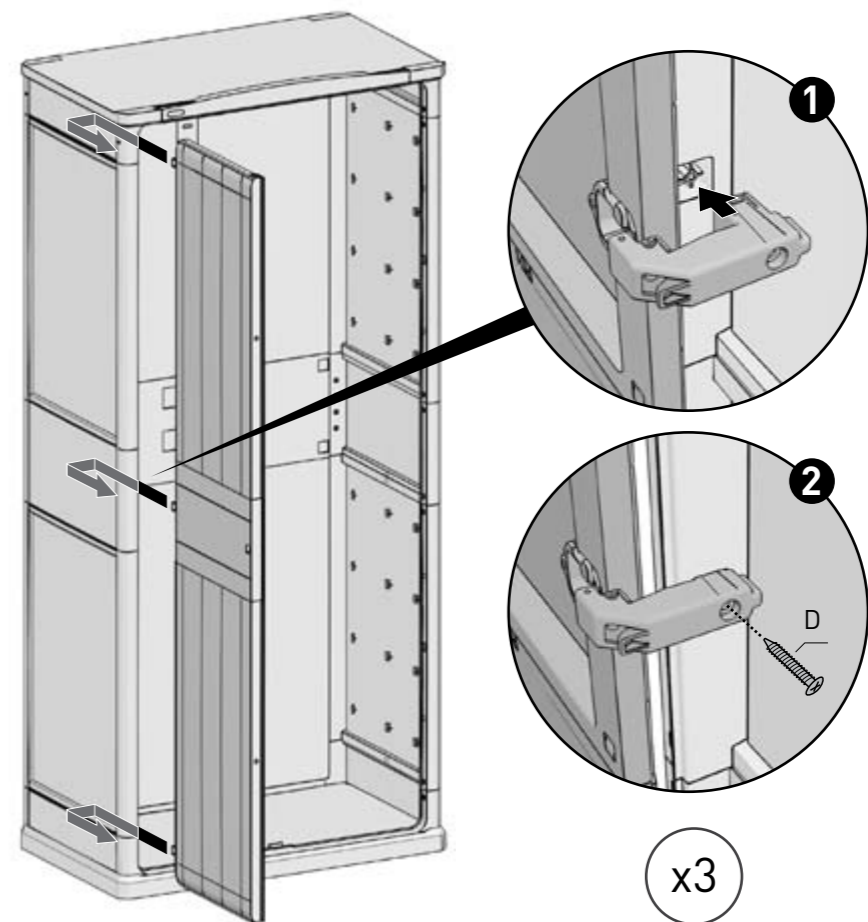

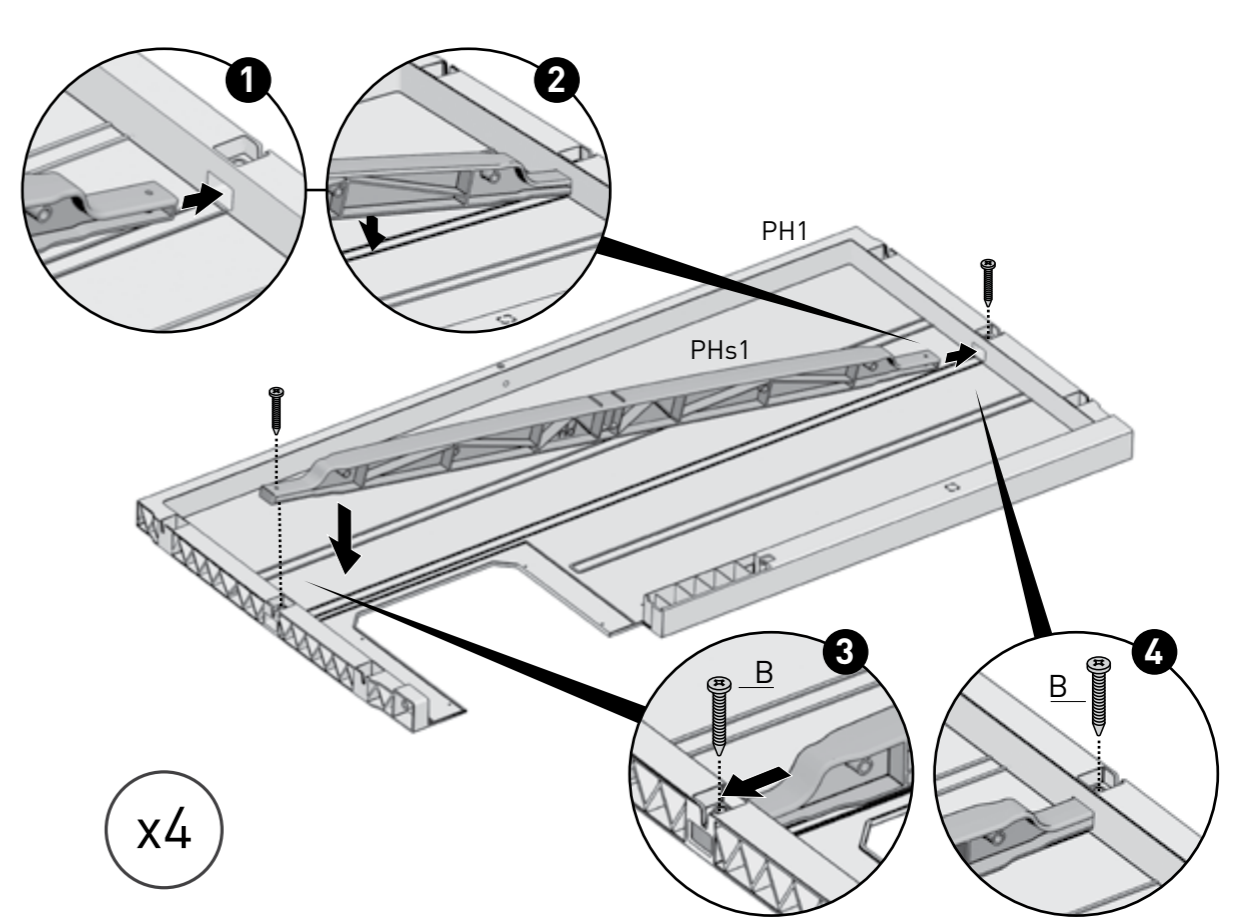
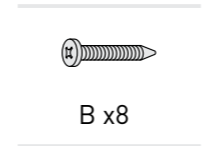
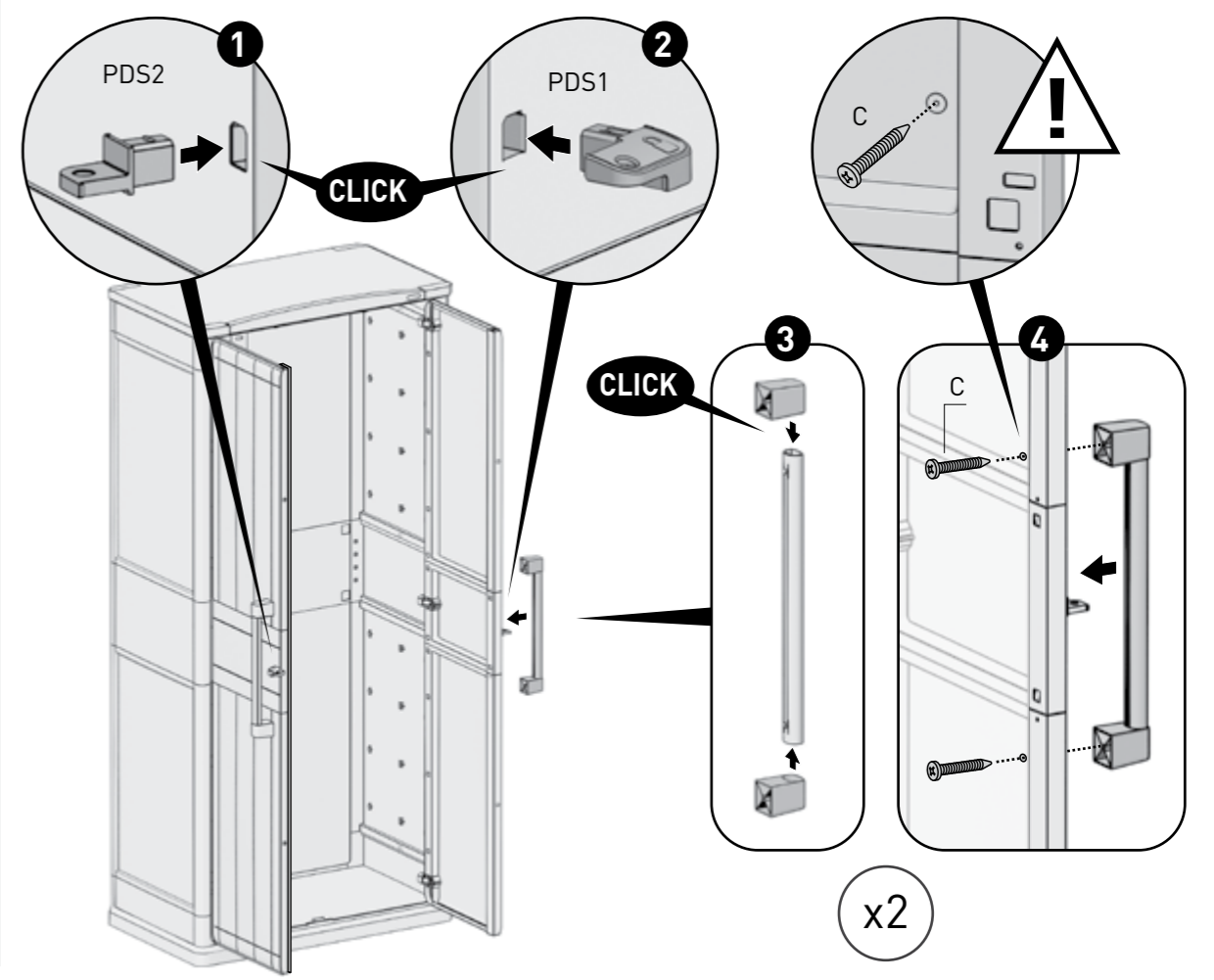
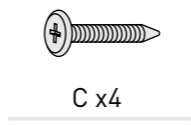
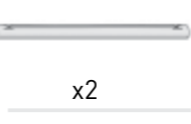
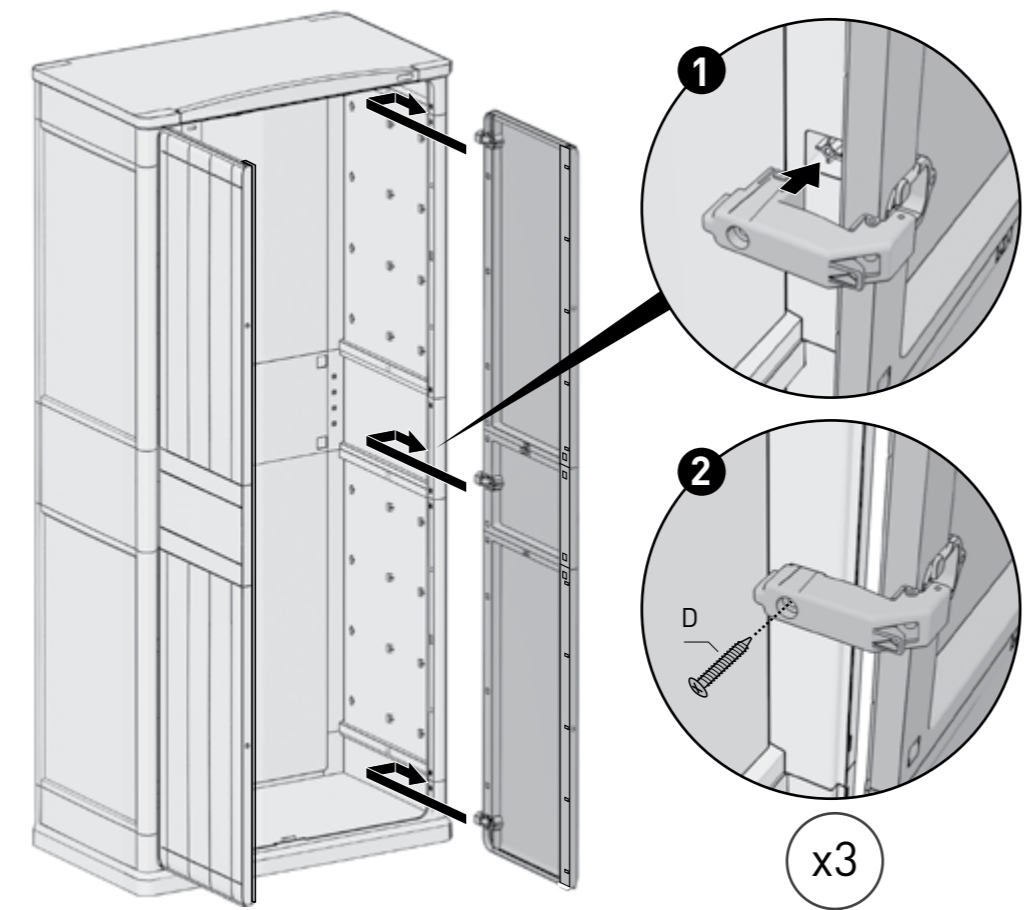
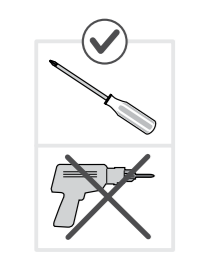
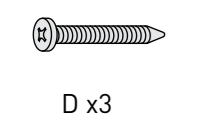
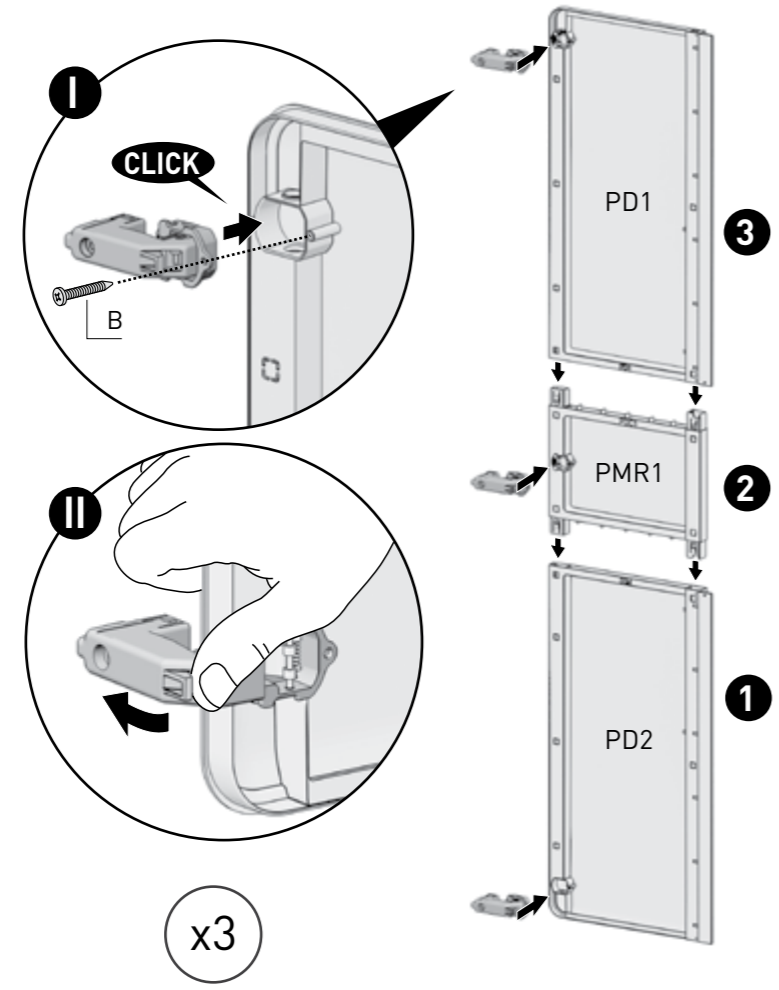
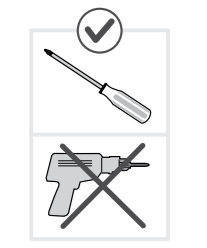
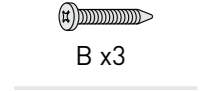



PF x4



B x8

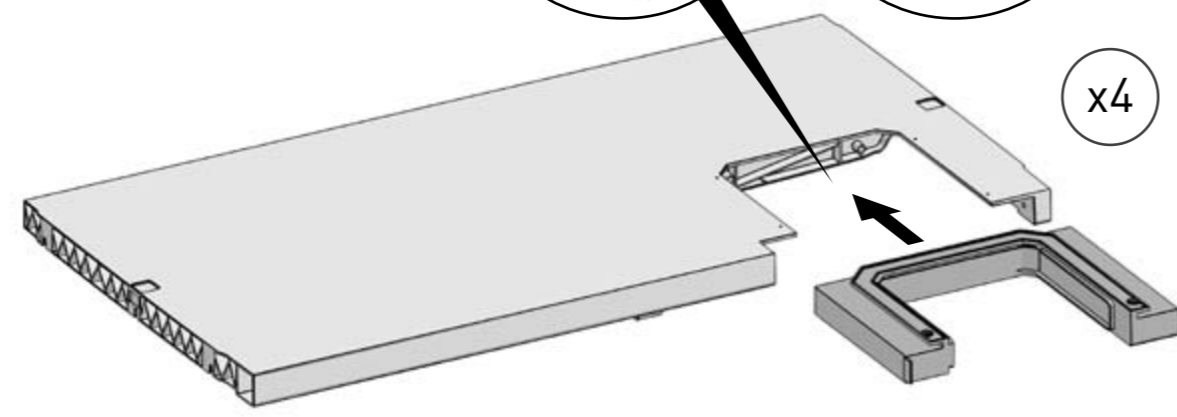
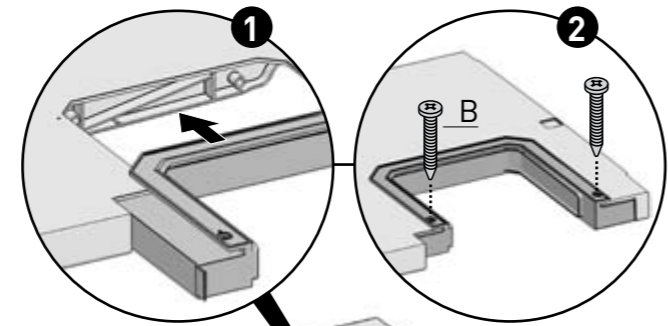
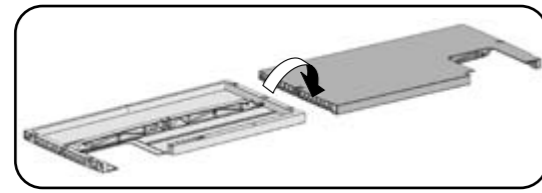

PN1 x1



PN2 x1



PN3 x1

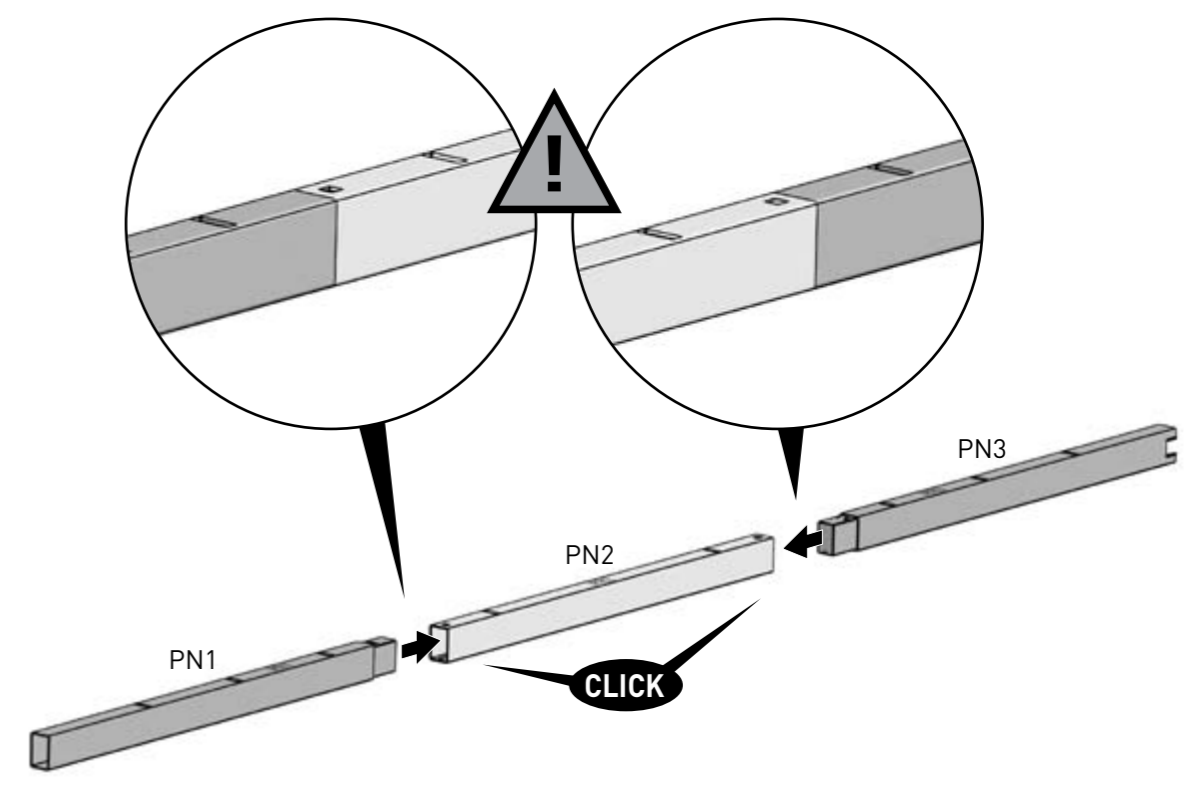

D x16

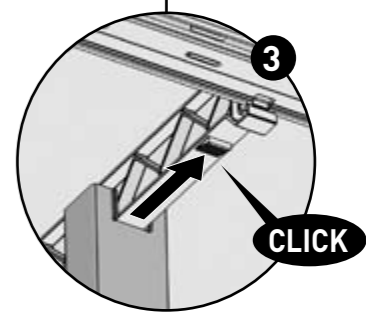
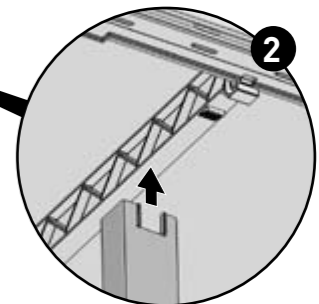
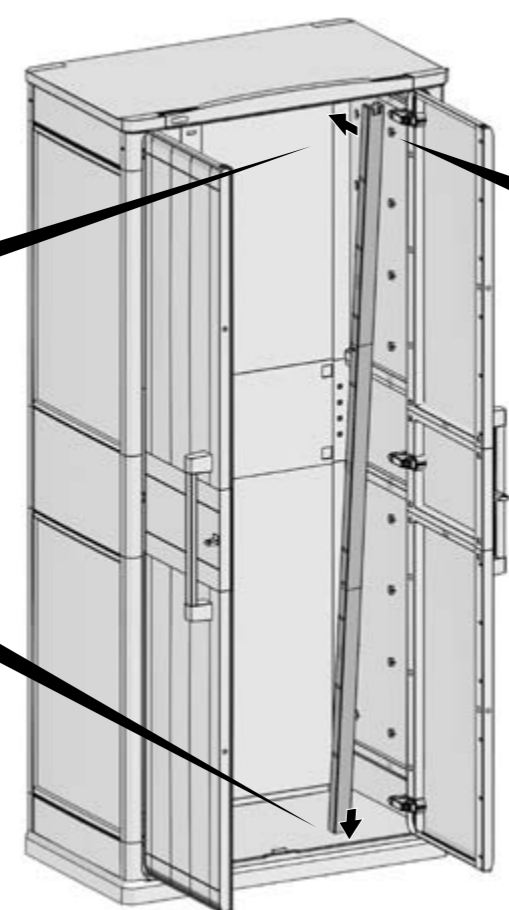
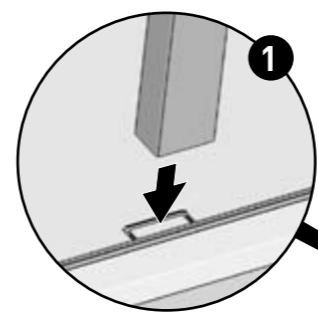
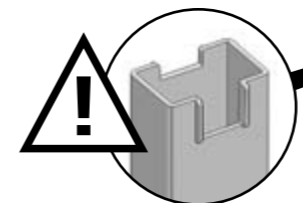
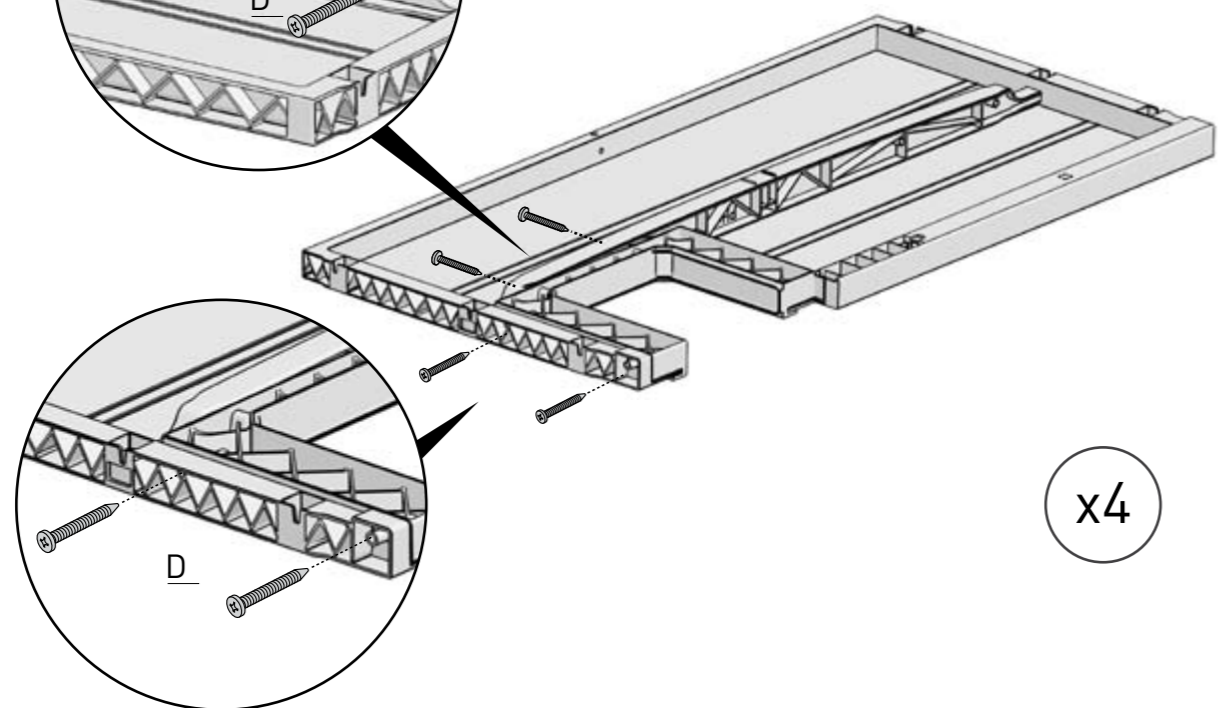
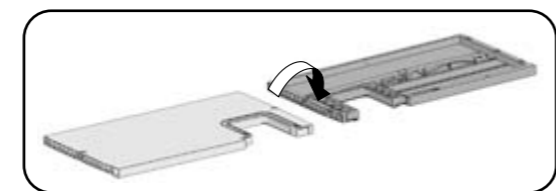
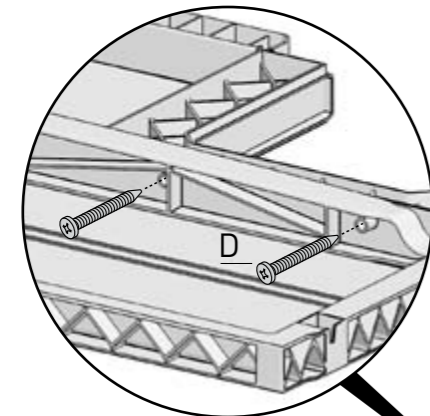





x8

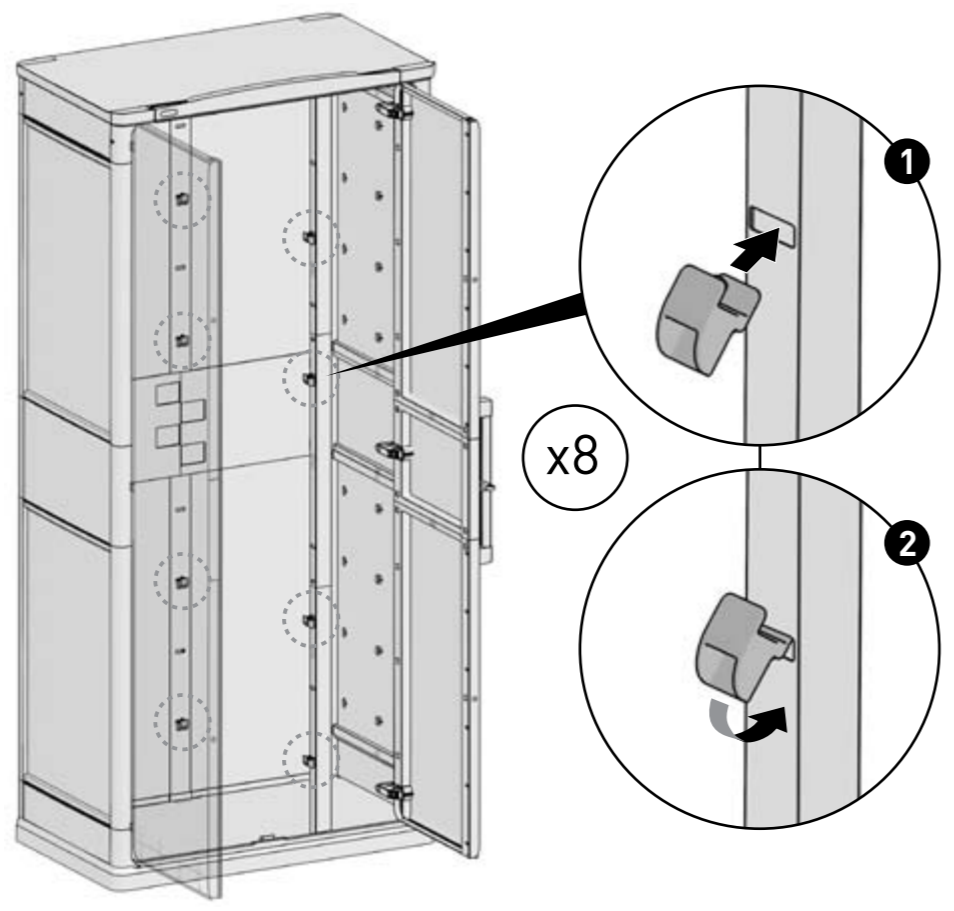

PX x4

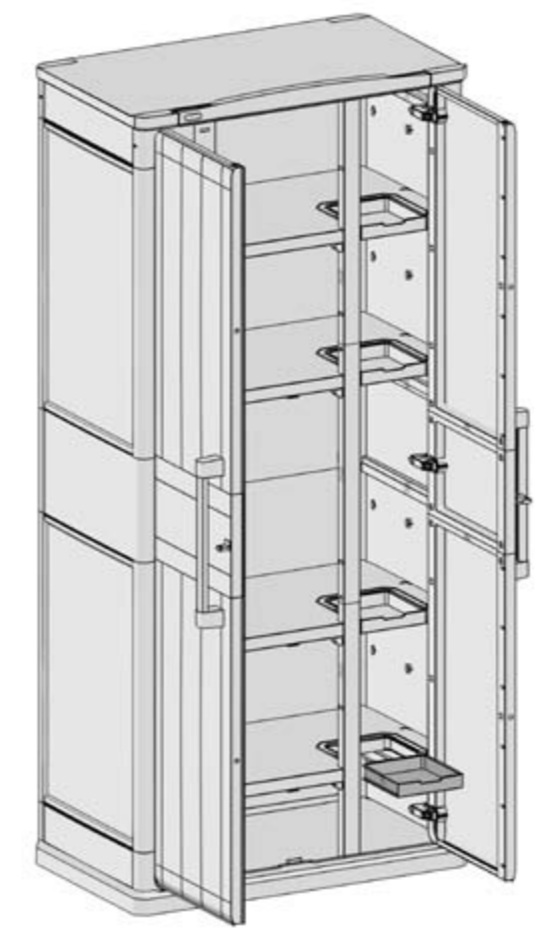

OPTION 1

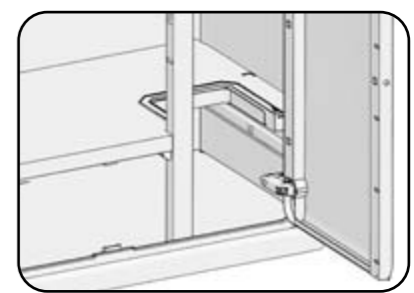

OPTION 2

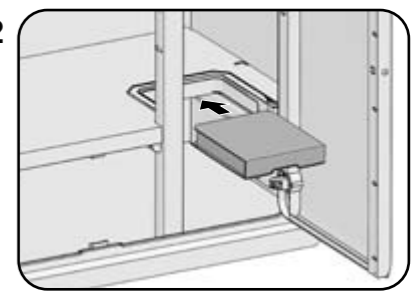

OPTION 3

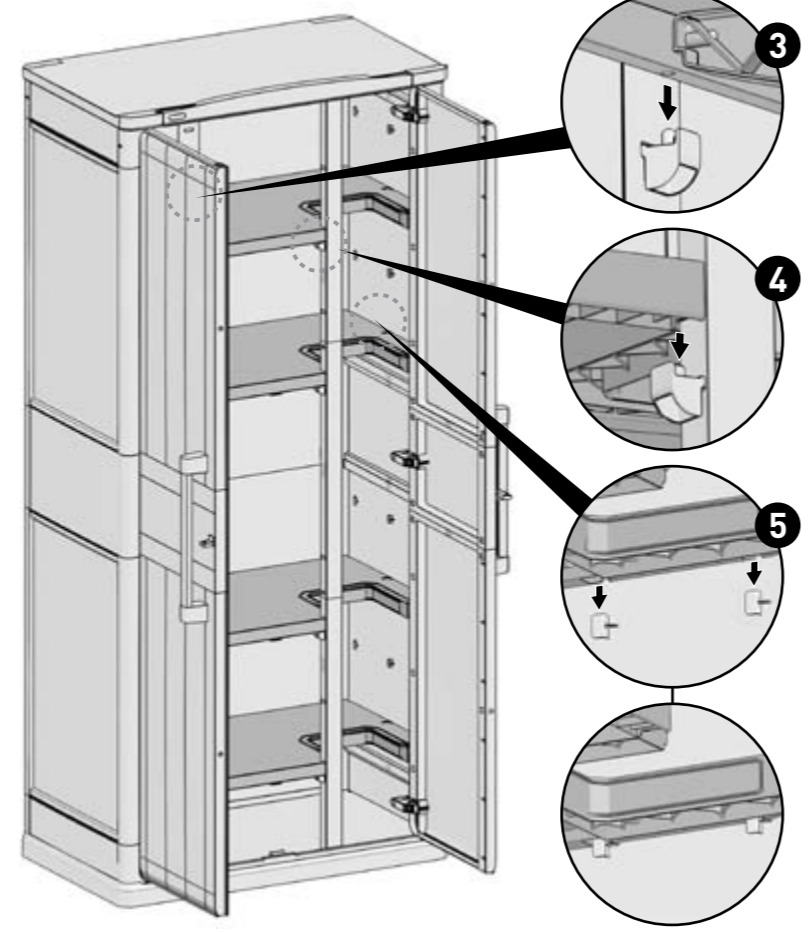
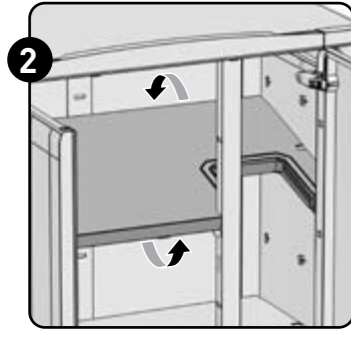
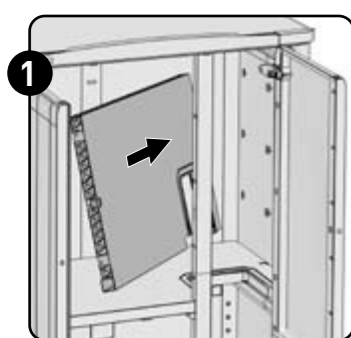
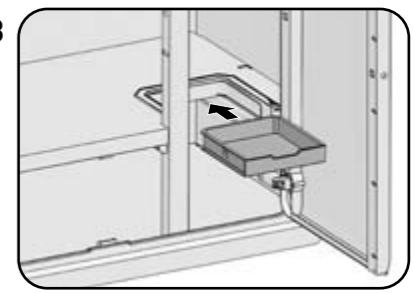

x4

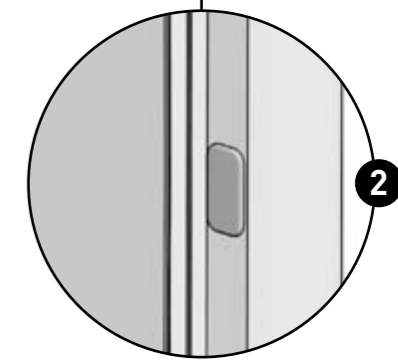
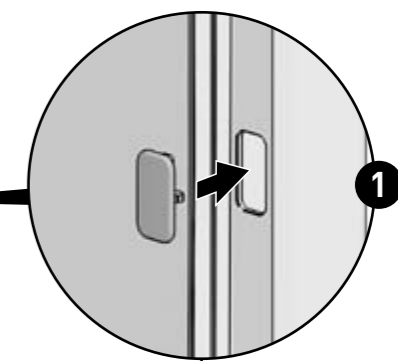
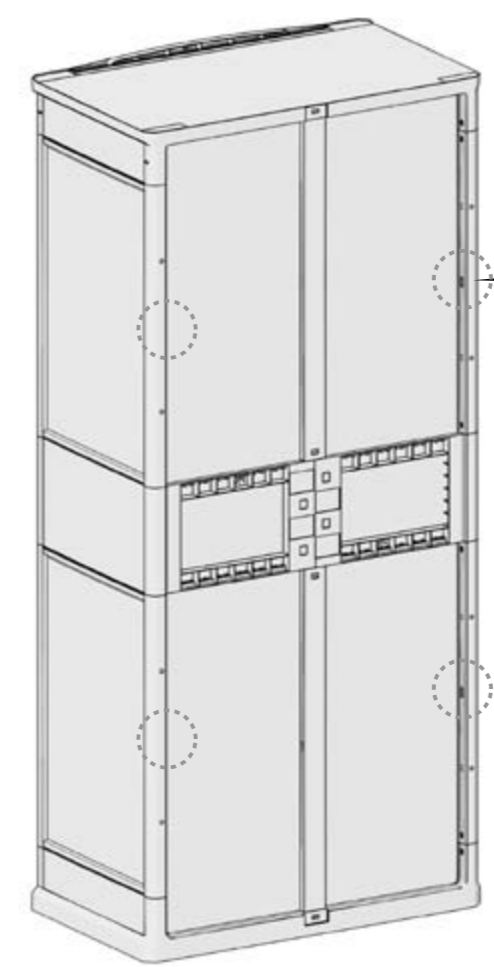

x4

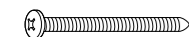
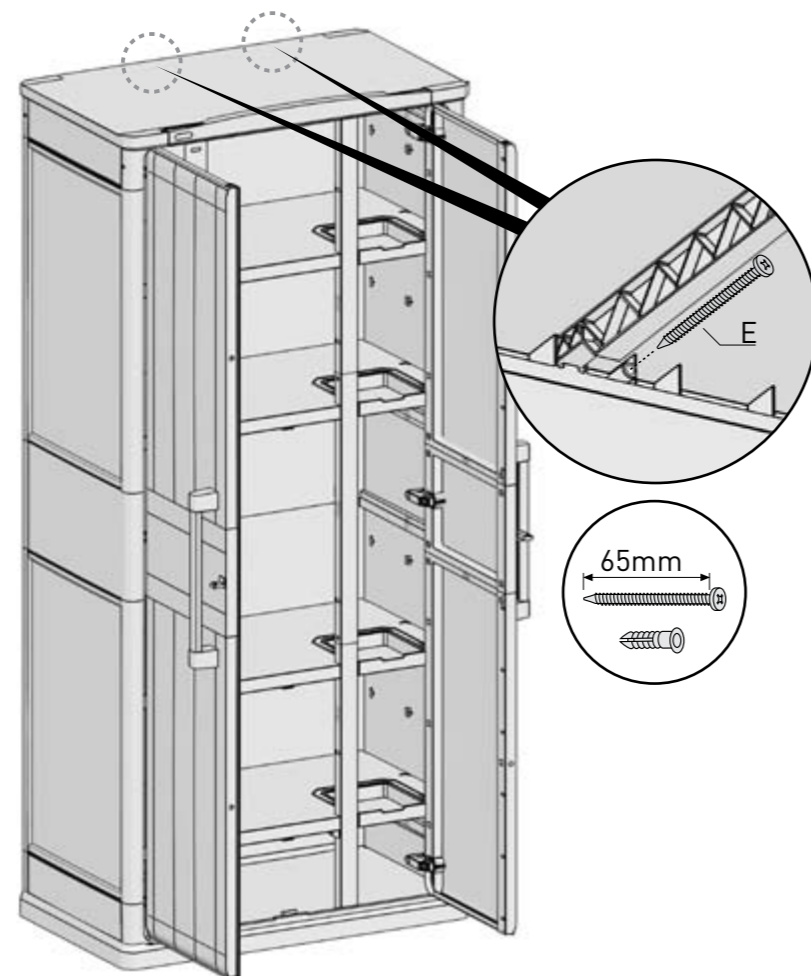

Ex2

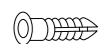

x2

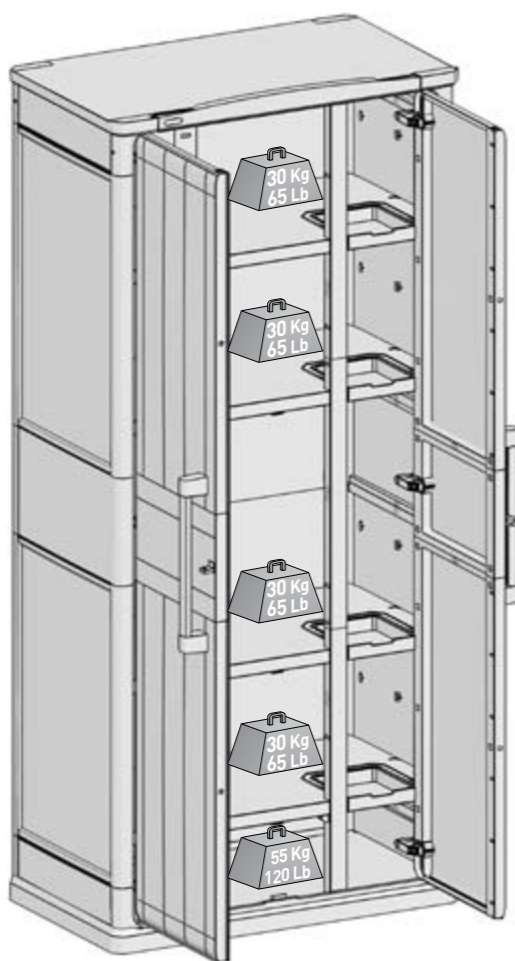

## EN CARE AND SAFETY GUIDELINES

- The shed is intended for storage purposes only.
- It is strongly recommended to secure the shed to the wall (at the pre-marked locations) and inserting proper screws into the ground (screws are not included).
- Periodically check the shed to ensure that it is stable and that the site is level.
- When assembling or handling the shed, use only those tools listed in the user manual.
- Avoid using a lawnmower or mechanical scythe near the shed.
- follow the manufacturer's instructions when using power tools.
- Wash the shed with a garden hose or a mild detergent solution. Do not use a stiff brush or abrasive cleaners, including degreasers and oil - or acetone-based cleaning materials, as these may stain or damage the shed.
- Do not store hot items, such as recently used grills and blowtorches, and volatile chemicals in the shed.
- Avoid placing heavy items against the external walls, as this may cause distortion.
- Keep the roof clear of accumulated snow and leaves. Large amounts of snow on the roof can damage the shed, making it unsafe to enter.
- Wind direction is an important factor to consider when determining the location of the shed. Reduce exposure to the wind, in general, and of the door side in particular. Keep doors closed and locked when the shed is not in use to prevent wind damage.
- Do not stand on the roof.
- Consult your local authorities to check if permits are required to erect the shed

## FR ENTRETIEN ET CONSIGNES DE SÉCURITÉ

- Cette armoire de jardin est destinée à des fins d'entreposage uniquement.
- Il est fortement recommandé de fixer l'armoire de jardin au mur (aux emplacements prédéfinis) et d'insérer les vis appropriées dans le sol (les vis ne sont pas incluses).
- Vérifiez régulièrement l'armoire de jardin et assurez-vous qu'elle est stable et que l'emplacement est toujours plat.
- Lors du montage et de la manipulation de l'armoire de jardin, utilisez uniquement les outils mentionnés dans le manuel de l'utilisateur.
- N'utilisez pas de tondeuse à gazon ou de coupe-bordures à proximité de l'armoire de jardin.
- Suivez les instructions du fabricant lorsque vous utilisez des outils électriques.
- Lavez l'armoire de jardin à l'aide d'un tuyau d'arrosage ou avec un détergent doux dilué. N'employez pas de brosse dure ou de nettoyeurs abrasifs, y compris des dégraissants tels que des produits nettoyants à base d'huile ou d'acétone, car ils pourraient tacher ou abîmer l'armoire de jardin.
- N'entrez pas d'objets chauds, comme des grills ou des lampes à souder que vous venez d'utiliser, ni de produits chimiques volatils dans l'armoire de jardin.
- N'appuyez pas d'objets lourds contre les parois externes, car cela pourrait causer une déformation.
- Ne laissez pas la neige ou des feuilles s'accumuler sur le toit. Une grande quantité de neige sur le toit pouvant abîmer l'armoire de jardin et la rendre dangereuse d'accès.
- La direction du vent est un facteur important dont il faut tenir compte au moment d'installer l'armoire de jardin. Réduisez l'exposition au vent en général, et plus particulièrement pour le côté où se trouve la porte. Gardez les portes closes et verrouillées quand vous n'utilisez pas l'armoire de jardin, afin d'éviter des dégâts dus au vent.
- Ne montez pas sur le toit.
- Consultez les autorités locales pour vérifier si l'installation de l'armoire de jardin nécessite un permis.

## GE PFLEGE - UND SICHERHEITSRICHTLINIEN

- Der Schuppen ist nur für Lagerungszwecke vorgesehen.
- Wir empfehlen ausdrücklich, den Schuppen an der Wand zu befestigen (an den vormarkierten Stellen) und mit geeigneten Schrauben im Boden zu verankern (Schrauben nicht beigelegt).
- Überprüfen Sie den Schuppen von Zeit zu Zeit, um sicherzustellen, dass er stabil und der Boden eben geblieben ist.
- Verwenden Sie nur die im Handbuch aufgeführten Werkzeuge bei Montage und Handhabung des Schuppens.
- Vermeiden Sie die Benutzung eines Rasenmähers oder einer Motorsense in Schuppennähe.
- Bei der Benutzung von Elektrowerkzeugen beachten Sie bitte die Anweisungen des Herstellers.
- Waschen Sie den Schuppen mit einem Gartenschlauch oder einer milden Reinigungslösung. Keine Scheuerbürsten, Scheuermittel, einschließlich Fettlöser und Reiniger auf Öl- oder Aceton-Basis verwenden, da diese Flecken hinterlassen oder den Schuppen beschädigen können.
- Keine heißen Gegenstände, wie ein gerade benutzter Grill oder Lötlampen oder leichtflüchtige Chemikalien im Schuppen lagern.
- Vermeiden Sie es, schwere Gegenstände gegen die Außenwände zu lehnen, da dies zu Verformungen führen kann.
- Das Dach frei von Schnee und Blättern halten. Große Schneemengen auf dem Dach können den Schuppen beschädigen, so dass das Betreten nicht mehr sicher ist.
- Die Windrichtung ist ein wichtiger Faktor bei der Standortbestimmung für den Schuppen. Vermeiden Sie generell, dass der Schuppen und vor allem die Tür nicht dem Wind ausgesetzt sind. Zur Vermeidung von Windschäden muss die Schuppentür bei Nichtbenutzung stets abgeschlossen sein.
- Nicht auf dem Dach stehen.
- Erkundigen Sie sich bei den örtlichen Behörden, ob für die Aufstellung des Schuppens eine Genehmigung erforderlich ist.

## ES DIRECTRICES DE CUIDADO Y SEGURIDAD

- El cobertizo ha sido concebido únicamente para almacenamiento.
- Se recomienda encarecidamente asegurar el cobertizo a la pared (en los lugares previamente marcados) e introducir los tornillos adecuados en el suelo (tornillos no incluidos).
- Revisar el cobertizo periódicamente para asegurarse de que permanece estable y de que el lugar está nivelado.
- Durante el montaje o manipulación del cobertizo, se recomienda utilizar únicamente las herramientas indicadas en el manual de usuario.
- Evitar el uso de cortadoras de césped o guadañas mecánicas cerca del cobertizo.
- Seguir las instrucciones del fabricante al usar herramientas eléctricas.
- Lavar el cobertizo con una manguera de jardín o un detergente suave. No usar cepillos de cerdas duras o limpiadores abrasivos, incluidos desengrasantes o materiales de limpieza hechos a base de aceites o acetona, ya que podrían manchar o dañar el cobertizo.
- No almacenar en el cobertizo elementos calientes, tales como parrillas y sopletes acabados de usar, o productos químicos volátiles.
- Evitar apoyar elementos pesados sobre las paredes exteriores ya que esto podría provocar deformación.
- Mantener el tejado limpio de nieve y hojas. Grandes cantidades de nieve acumuladas en el tejado podrían dañar el cobertizo, haciendo que no sea seguro entrar.
- Es importante tener en cuenta la dirección del viento en el momento de decidir la situación del cobertizo. Reducir la exposición al viento, en general, y la exposición del lado de la puerta en particular. Mantener las puertas cerradas y bloqueadas cuando no se utilice el cobertizo para evitar que el viento cause daños.
- No subirse al tejado.
- Consultar a las autoridades locales para saber si se requiere algún tipo de permiso para montar el cobertizo.

## IT ONDERHOUDS- EN VEILIGHEIDSRICHTLIJNEN

- Het schuurtje is alleen bedoeld voor opslagdoeleinden.
- Het wordt ten zeerste aangeraden om het schuurtje aan de muur (bij vooraf gemarkeerde locaties) vast te zetten en de juiste schroeven in de grond te plaatsen (schroeven zijn niet inbegrepen).
- Controleer het schuurtje regelmatig om te verzekeren dat het stabiel is en dat de locatie egaal is.
- Gebruik bij het monteren of hanteren van het schuurtje, alleen die gereedschappen die in de gebruikershandleiding worden genoemd.
- Vermijd het gebruik van een grasmaaier of mechanische zeis in de buurt van het schuurtje.
- Volg de instructies van de fabrikant als u elektrisch gereedschap gebruikt.
- Was het schuurtje met een tuinslang of een oplossing met mild reinigingsmiddel af. Gebruik geen stijve borstel of schuurmiddelen, inclusief ontvettingsmiddelen en op olie en aceton gebaseerde reinigingsmiddelen. Deze kunnen vlekken of schade aanbrengen aan het schuurtje.
- Sla in het schuurtje geen warme voorwerpen op, zoals onlangs gebruikte barbecues en branders, of vluchtige chemicaliën.
- Voorkom het plaatsen van zware voorwerpen tegen buitenmuren. Dit kan vervorming veroorzaken.
- Houd het dak vrij van opgestapelde sneeuw en blad. Grote hoeveelheden sneeuw op het dak, kan het schuurtje beschadigen en het onveilig voor toegang maken.
- Windrichting is een belangrijke factor om in beschouwing te nemen als u de locatie van het schuurtje bepaalt. Verminder over het algemeen blootstelling aan wind en vooral blootstelling van de deurzijde. Houd deuren gesloten en op slot als het schuurtje niet wordt gebruikt. Dit voorkomt schade door wind.
- Niet op het dak staan.
- Raadpleeg uw plaatselijke instanties om te controleren of u een vergunning nodig hebt om het schuurtje te bouwen.

## NL LINEE GUIDA PER LA MANUTENZIONE E LA SICUREZZA

- Il capanno deve essere utilizzato solo come deposito.
- È fortemente raccomandato il fissaggio al muro (nei punti contrassegnati) e al suolo tramite l'utilizzo di viti appropriate (le viti non sono incluse).
- Controllare periodicamente il capanno per assicurarsi che sia stabile e che il piano su cui poggia sia ben livellato.
- Nell'assemblare o modificare il capanno utilizzare solo gli utensili indicati nel manuale d'uso.
- Evitare l'utilizzo di tagliaerba e falci meccaniche nei pressi del capanno.
- Seguire le istruzioni del produttore nell'utilizzo di utensili elettrici.
- Lavare con una pompa da giardino o con una soluzione detergente non aggressiva. Non utilizzare spazzole rigide o detersivi abrasivi, inclusi sgrassatori e prodotti a base di olio o acetone, perché potrebbero macchiare o danneggiare il capanno.
- Non riporre oggetti caldi, come griglie appena utilizzate e fiamme ossidriche, o prodotti chimici pericolosi all'interno del capanno.
- Evitare di appoggiare oggetti pesanti alle pareti esterne perché potrebbero provocare distorsioni.
- Evitare l'accumulo di neve e foglie sul tetto del capanno. Grosse quantità di neve sul tetto possono danneggiare il capanno rendendolo poco sicuro per l'accesso.
- La direzione del vento rappresenta un fattore rilevante per determinare la locazione del capanno. Ridurre l'esposizione al vento del capanno in generale ma soprattutto l'esposizione della porta. Lasciare sempre le porte chiuse a chiave quando il capanno non viene utilizzato per prevenire eventuali danni causati dal vento.
- Non sostare sul tetto.
- Consultare le autorità locali per verificare se ci sia bisogno di permessi per l'installazione del capanno.

## PT ORIENTAÇÕES PARA MANUTENÇÃO E SEGURANÇA

- O abrigo destina-se apenas para fins de armazenamento.
- Recomenda-se vivamente fixar o abrigo à parede (nas posições pré-marcadas) e introduzir os parafusos apropriados no solo (os parafusos não estão incluídos).
- Verifique periodicamente o abrigo para assegurar-se de que está estável e nivelado.
- Ao manusear ou durante a montagem do abrigo, use apenas as ferramentas indicadas no manual do utilizador.
- Evite usar corta-relvas ou foices mecânicas perto do abrigo.
- Siga as instruções do fabricante ao usar ferramentas eléctricas.
- Lave o abrigo com uma mangueira de jardim ou uma solução de detergente suave. Não utilize uma escova dura ou líquidos de limpeza abrasivos, incluindo desengordurantes ou materiais de limpeza à base de óleo ou acetona, uma vez que estes podem manchar ou danificar o abrigo.
- Não armazene artigos quentes, tais como grelhadores e maçaricos recentemente utilizados, ou produtos químicos voláteis no abrigo.
- Evite colocar artigos pesados de encontro às paredes exteriores, uma vez que pode provocar deformações.
- Mantenha o telhado limpo da neve e das folhas acumuladas. Grandes quantidades de neve no telhado podem danificar o abrigo, tornando o acesso ao respectivo interior pouco seguro.
- O sentido do vento é um fator importante a considerar ao determinar o local de colocação do abrigo. Reduza a exposição ao vento, em geral e, sobretudo, do lado da porta. Mantenha as portas fechadas e trancadas quando o abrigo não está a ser utilizado para prevenir danos causados pelo vento.
- Não se coloque em pé no telhado.
- Consulte as suas autoridades locais para verificar se são licenças para colocar o abrigo.

## GR ΟΔΗΓΙΕΣ ΦΡΟΝΤΙΔΑΣ ΚΑΙ ΑΣΦΑΛΕΙΑΣ

- Το υπόστεγο προορίζεται μόνο για σκοπούς αποθήκευσης.
- Προτείνεται αυστηρά να στερεώσετε το υπόστεγο στον τοίχο (σε προ-σημειωμένες θέσεις) και εισαγάγετε κατάλληλες βίδες στο έδαφος (οι βίδες δεν περιλαμβάνονται).
- Ελέγχετε περιοδικά το υπόστεγο για να βεβαιωθείτε ότι είναι σταθερό και πως ο χώρος είναι επίπεδος.
- Κατά τη συναρμολόγηση ή το χειρισμό του υπόστεγου, χρησιμοποιήστε μόνο τα εργαλεία που αναφέρονται στο εγχειρίδιο χρήσης.
- Αποφύγετε τη χρήση χορτοκοπτική μηχανή ή μηχανικού δρεπάνου κοντά στο υπόστεγο.
- Ακολουθείτε τις οδηγίες του κατασκευαστή όταν χρησιμοποιείτε ηλεκτρικά εργαλεία.
- Πλένετε το υπόστεγο με λάστιχο κήπου ή ήπιο διάλυμα απορρυπαντικού. Μη χρησιμοποιείτε σκληρή βούρτσα ή λειαντικά καθαριστικά, συμπεριλαμβανομένων απολιπαντικών και υλικών καθαρισμού με βάση πετρέλαιο ή ακετόνη, καθώς μπορεί να λεκιάσουν ή να καταστρέψουν το υπόστεγο.
- Μην αποθηκεύετε αντικείμενα υψηλής θερμοκρασίας, όπως ψησταριές και καμινέτα που έχουν χρησιμοποιηθεί πρόσφατα, ή πτητικές χημικές ουσίες στο υπόστεγο.
- Αποφεύγετε την τοποθέτηση βαρέων αντικειμένων έναντι των εξωτερικών τοίχων, καθώς αυτό μπορεί να προκαλέσει παραμόρφωση.
- Καθαρίζετε τη στέγη από συσσωρευμένο χιόνι και φύλλα. Μεγάλες ποσότητες χιονιού στη στέγη μπορούν να προκαλέσουν καταστροφή στο υπόστεγο, καθιστώντας το επισφαλές για να εισέλθετε.
- Η κατεύθυνση του ανέμου αποτελεί σημαντικό παράγοντα κατά τον καθορισμό της θέσης του υπόστεγου. Μειώστε την έκθεση στον αέρα, σε γενικές γραμμές, και την έκθεση της πλευρικής πόρτας ειδικότερα. Διατηρείτε τις πόρτες κλειστές και κλειδωμένες όταν το υπόστεγο δεν χρησιμοποιείται, για πρόληψη φθορών από ανέμους.
- Μη στέκεστε πάνω στη στέγη.
- Συμβουλευτείτε τις τοπικές Αρχές σας για να ελέγξετε αν απαιτούνται άδειες για τοποθέτηση του υπόστεγου.

After assembly is completed there may be extra small parts, you may dispose of these as they are not needed | Une fois l'assemblage terminé, il se peut que vous ayez quelques petites pièces en trop dont vous pouvez vous débarrasser car elles ne sont pas nécessaires | Sollten nach dem Zusammenbau kleinere Plastikteile übrig geblieben sein, so können Sie diese entsorgen | Finalizado el montaje, pueden sobrar algunas piezas, puede disponer de ellas pues no son necesarias | A montaggio ultimato possono avanzare alcune piccole parti, queste possono essere smaltite perché non sono necessarie | Voor de zekerheid zijn extra kleine onderdelen toegevoegd, de onderdelen die teveel zijn ontvangen mag u weggoien bij uw huisafval | Concluído a assembleia, eles podem ter alguns pedaços mais que suficiente, pode os ter porque eles não são necessários | Όταν η συναρμολόγηση έχει ολοκληρωθεί μπορεί να υπάρχουν επιπλέον μικρά κομμάτια που δεν χρειάζονται, μπορείτε να τα διαθέσετε στα άχρηστα