

VENTS Modern Series



Axial fans for exhaust ventilation with the capacity up to 310 m³/h.

Applications

- Continuous or periodic exhaust ventilation of bathroom, showers, kitchens and other utility spaces.
- Ventilation shaft mounting or duct connection.
- Low to medium air flow motion for short distances at low air resistance.
- Compatible with 100, 125 and 150 mm air ducts.

Design

- Modern design and aesthetic look.
- The casing and the impeller are made of high-quality durable ABS plastic, UV resistant.
- The front panel from organic glass.
- The intellectual impeller design makes the fan efficiency high and the service life long.
- Protection rating IP 34.

Motor

- Reliable and low-watt electric motor.
- Designed for continuous operation and requires no maintenance.
- Equipped with overheating protection.

Modifications and Options



Modern K – fan is equipped with a backdraft damper for back flow preventing.



Modern L – the motor is equipped with ball bearings for long service life (appr. 40 thousand hours) and fan mounting at any angle. The bearings are maintenance-free and contain enough grease for the entire operating period.



Modern turbo – high-powered motor.



Modern 12 – modification with low-voltage motor. 12 V AC power supply.



Modern T – equipped with a regulated timer with the operating time from 2 to 30 minutes.



Modern TH – equipped with a timer with the operating time from 2 to 30 minutes and a humidity sensor with the threshold value from 60 to 90%.



Modern V – equipped with a pull cord switch.



Modern VT – equipped with a pull cord switch and a regulated timer with the operating time adjustable from 2 to 30 minutes.



Modern VTH – equipped with a pull cord switch, regulated timer with the operating time adjustable from 2 to 30 minutes and a humidity sensor with the operating threshold range from 60% to 90%.

Control

Manual:

- The fan is controlled by a room light switch. It is not included in the delivery package.
- The fan is controlled by the built-in pull cord switch **V**. Not applied in case of ceiling mounting.
- Speed control is possible through a thyristor speed controller (see Electrical Accessories). Several fans may be connected to the same regulator unit.

Automatic:

- By the electronic control unit **BU-1-60** (see Electrical Accessories). The control unit is supplied separately.
- By the timer **T** (the built-in run-out timer enables the fan operation within 2 to 30 minutes after the fan switching off).
- By the humidity sensor and timer **TH** (if the humidity level in the room exceeds the sensor threshold adjustable value within 60-90% the fan switches automatically on and operates until the humidity level drops to the standard level, after that the fan continues operating within the time period according to the timer setting, then shuts down).

Mounting features

- The fan is mounted directly into the ventilation shaft.
- Flexible duct application is recommended in case of remote location of the ventilation shaft. The air duct is connected to the fan exhaust flange through a clamp.
- Fixed to wall by self-tapping screws.
- Suitable for ceiling mounting.
- For 12 V low-voltage motor fan connection to 220 V / 50 Hz power mains use the step-down transformer TRF 220/12-25 that is available upon separate order.

Accessories



Air ducts

Grilles and hoods

Backdraft damper

Speed controllers

Clamps

Aerodynamic characteristics

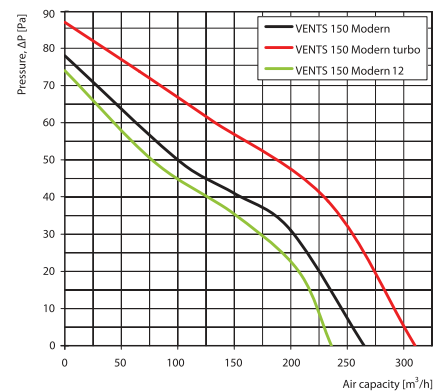
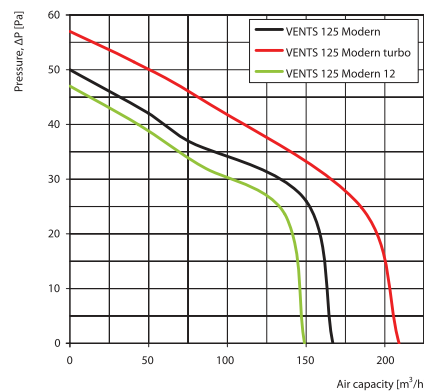
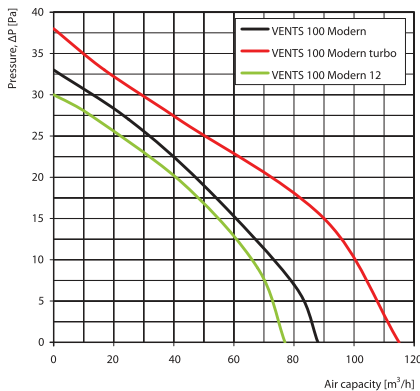

Technical data

Model	Voltage [V] at 50 Hz	Power Consumption [W]	Current [A]	r.p.m.	Maximum air capacity [m³/h]	Sound Pressure Level at 3m [dB(A)]	Weight [kg]
VENTS 100 Modern	220-240	14	0,085	2300	88	33	0,60
VENTS 125 Modern	220-240	16	0,1	2400	167	34	0,74
VENTS 150 Modern	220-240	24	0,13	2400	265	37	0,96
VENTS 100 Modern turbo	220-240	16	0,1	2300	115	36	0,68
VENTS 125 Modern turbo	220-240	24	0,105	2400	209	36	0,84
VENTS 150 Modern turbo	220-240	30	0,13	2400	310	39	1,10
VENTS 100 Modern 12	12	14	1,5	2200	77	32	0,59
VENTS 125 Modern 12	12	16	1,7	2300	149	33	0,72
VENTS 150 Modern 12	12	24	2	2300	236	36	0,92

Mounting examples



Overall dimensions

Model	Dimensions [mm]			
	Ø D	B	L	L1
VENTS 100 Modern	100	170	130	35
VENTS 125 Modern	125	196	139	38
VENTS 150 Modern	150	226	157	39

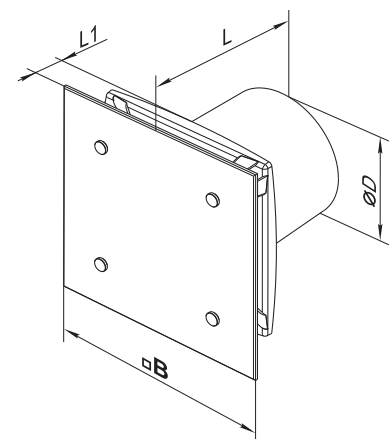

Certificates



The fans meet the applicable safety and electromagnetic compatibility standards.