

---

# *Product Specifications*

**NAME: Europe Standard Low-voltage Touch Panel Full-color Controller**

**MODEL: U-TM08ER**



## **I. Summarization**

Touch panel controller is a new high-end controller which newly developed by our company. It adopts glass panel design, is beautiful and fashionable in appearance. It adopts high precision capacitance touch control chip, increases the touch sensitivity, reduces trigger which caused by mistake. It is used for controlling a variety of lamp whose source of light is LED. For instance, point source of light, flexible light strip, panel lights etc., it has many advantages such as convenient to connect, easy to use and others.

## **II. Technical Parameters**

- working temperature: -20-60 °C
- supply voltage: DC12~24V
- output voltage: DC12~24V
- output: 3 channels
- connection mode: common anode
- external dimension: L80 X W80 X H41.8 mm
- packing size: L105 X W105 X H53 mm
- net weight: 130.6g
- gross weight: 181g
- static power consumption: <1W
- output current: <4A (each channel)
- output power: 12V<144W 24V<288W

## **III. External Dimension**

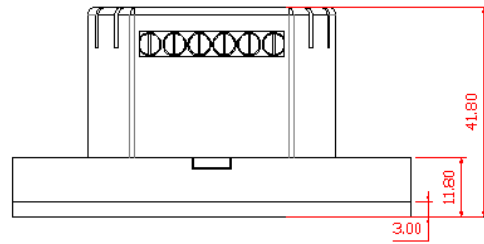
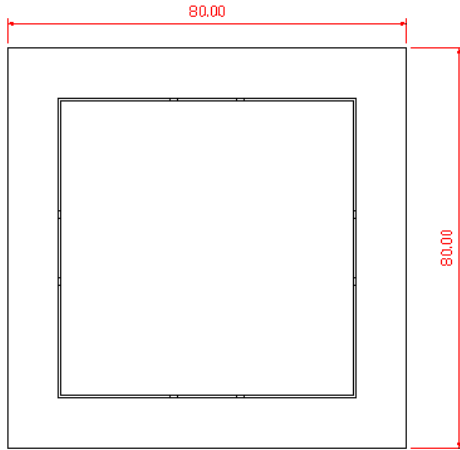

Unit: mm

#### IV. Interface Specifications

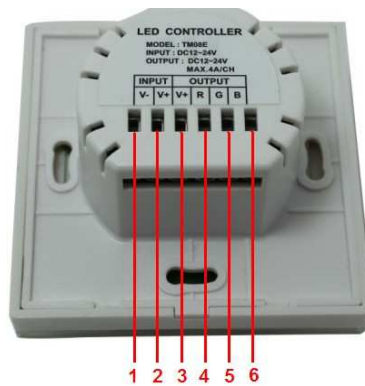

“1”, “2”: power input pins, input voltage range is 12-24V, “1” is negative pole, and “2” is positive pole.

“3”, “4”, “5”, “6”: power output pins, output voltage is 12-24V, maximum output current is 12A, “3” is positive pole, “4” is interface of red light, “5” is interface of green light, “6” is interface of blue light.

#### V. Instruction for use:



: in static mode, you can adjust brightness 0-255 quickly, up to 64 touch points, in dynamic mode, you can press it to switch to static mode.



: you could turn on/off controller at any state; When the dimmer is turned on, long press the key for 3 seconds, you can turn on/off output of buzzer;



: 19 kinds of dynamic mode switching cyclically;



: 20 kinds of static mode switching cyclically;



: in static mode, brightness reduce key, total 255 levels; in dynamic mode, speed reduce key, total 10

levels;



: in static mode, brightness increase key, total 255 levels; in dynamic mode, speed increase key, total 10

levels;

Dynamic mode is shown in the below table:

Mode No.	Function	Mode No.	Function	Mode No.	Function
1	red burst flashing	8	Three-color jumping	15	purple gradually fades
2	green burst flashing	9	six-color jumping	16	white gradually fades
3	blue burst flashing	10	red gradually fades	17	three-color gradually fades
4	yellow burst flashing	11	yellow gradually fades	18	seven-color gradually fades
5	white burst flashing	12	green gradually fades	19	seven-color gradual changing
6	Three-color burst flashing	13	cyan-blue gradually fades		
7	Three-color flashing	14	blue gradually fades		

Static mode is shown in the below table:

No.	Mode	No.	Mode	No.	Mode
1	Red	8	Cyan	15	Brown
2	Orange	9	Light-blue	16	White
3	Deep-yellow	10	Sky-blue	17	Ivory
4	Yellow	11	Blue	18	Pink-white
5	Light-yellow	12	Deep-blue	19	Yellow-white
6	Green	13	Blue-purple	20	Blue-white
7	Light green	14	Purple		

### Typical Application

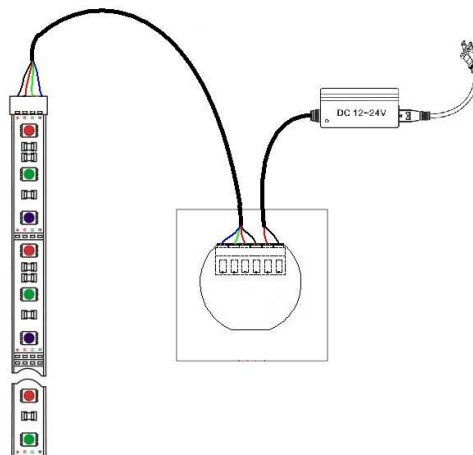

### Installation Method

1. open touch panel

Gently pry gaps in touch panel with a screwdriver, and then you can slowly remove the panel, as shown below;



## 2. wiring

Connect wiring according to typical application. Refer to typical application;

## 3. Install switch base

As shown in the picture, mount the controller on the cassette in the wall after connecting the wire, and then nail the screw, fix it on the wall, finally you can install the switch pedestal on the wall;

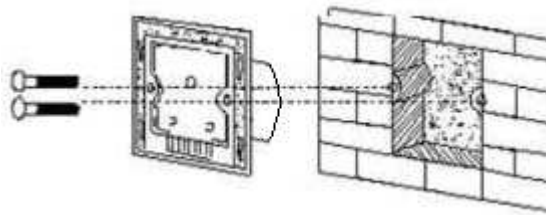

## Remarks

1. Connect the load wire at first, following by the power wire; **Please ensure short circuit can not occur between connecting wire before you turn on the power;**
2. The supply voltage of controller ranges in DC12-24V, it may burn out the controller once exceed the voltage.